

NOTE:

1. ALL DIMENSIONS ARE IN MILLIMETERS, BRACKETED DIMENSIONS ARE IN INCHES.
2. GENERAL TOLERANCES MAX.±0.20mm.
3. MATERIAL & □: SEE PAGE 3 OF 3.

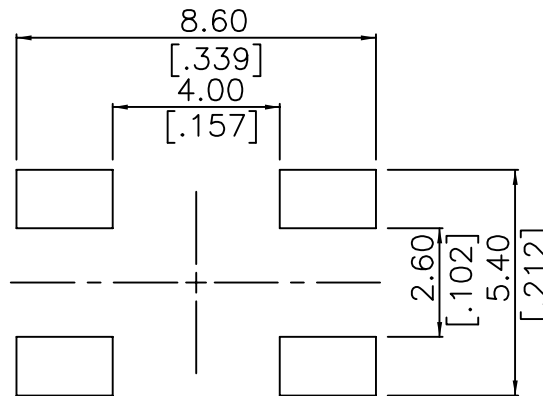

TSW66-V38J-xxx-LF
 LEADFREE
 FORCE
 180:180g
 260:260g
 360:360g

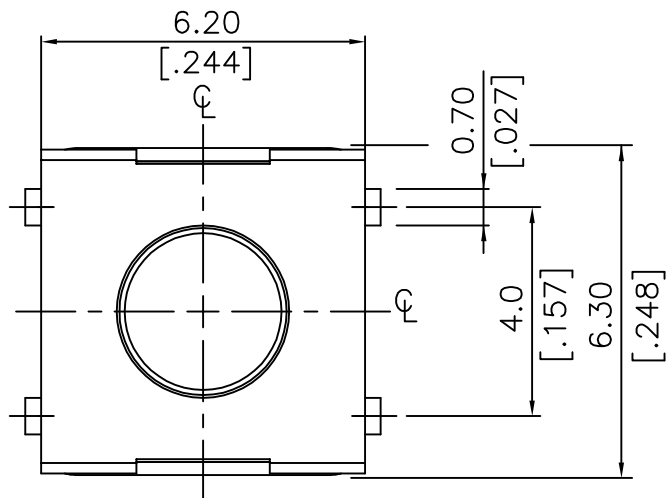
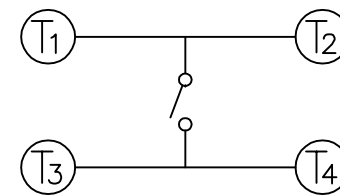

P.C.B. LAYOUT SCALE 8:1

CIRCUIT DIAGRAM

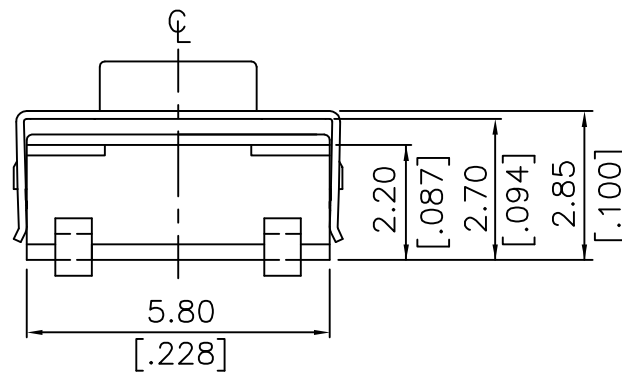
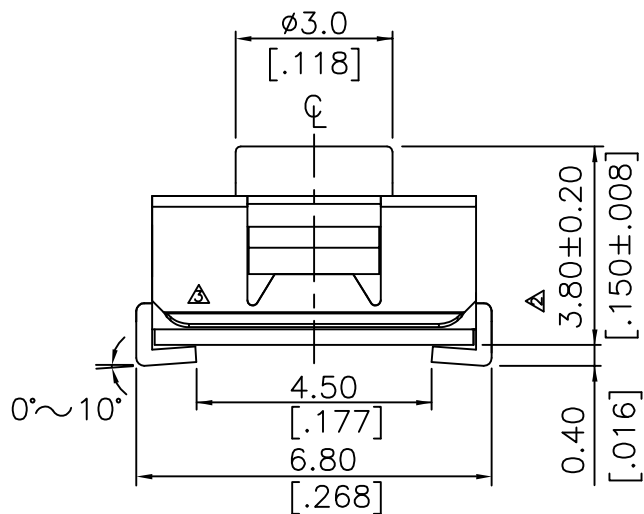

RoHS Compliant



PART NO. TSW66-V38J-xxx

DWG NO. TSW66-V38J-xxx

FILE NO.

UNIT / mm

SCALE 1:1

CHECKED BY CY

DRAWING BY

PROJECTION

TOLERANCES ARE

.X±0.2
 .XX±
 .XXX±
 AWG

DESCRIPTION:

AREA

**TACT SWITCH 6X6 WASHABLE
 J TYPE (H=3.80mm)**

REVISIONS

HK

DATE

煜倫股份有限公司