

P.C.B. LAYOUT

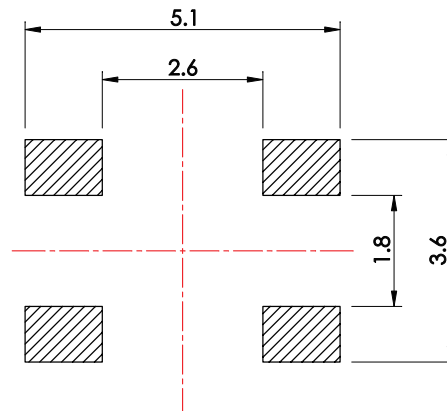

**SPECIFICATION**

**Rating:** 50mA 12V DC.

**Travel:** 0.2±0.1mm.

**Contact resistance:** 100mΩ Max.(initial)

**Operating force:** 250±50g.

**Minimum load:** 10mA 3.3V DC.(reference only)

**Life:** 100,000 Cycles Min.

**Soldering temperature:** 250°C Max. for 3 sec.

**Soldering time:** 1 time only.

**Note:** Unwashable, don't be immersed by epoxy and organic solvent.

CIRCUIT DIAGRAM

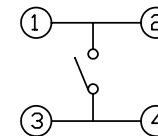

**RoHS Compliant**

TOLERANCES ARE

**MORETHANALL**  
PCB CONNECTORS  
Cable ASSEMBLIES

煜倫股份有限公司

www.morethanall.com

DRAWING BY CY

CHECKED BY GENIUS

UNIT/mm

SCALE 1:1

DATE

SIZE A4

X. ±  
.X ± 0.30  
.XX ± 0.20  
.XXX ±  
ANG ±

P PROJECTION

照片框

ORDER INFORMATION

TSW44-V05-250-LF

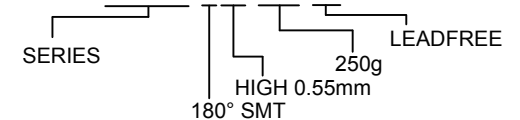

DESCRIPTION: