

P.C.B LAYOUT

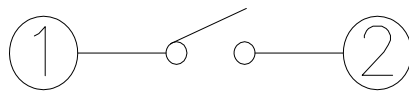

CIRCUIT DIAGRAM

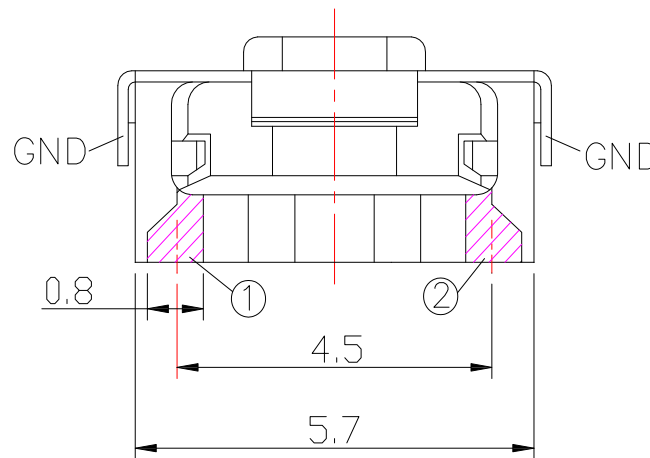

SPECIFICATIONS

Rating	DC 12V 50mA
Contact Resistance	100mΩ Max.
Insulation Resistance	100MΩ Min
Travel	0.25±0.1mm
Operating Force	2   160 ± 50gf   3   250 ± 50gf
Operating Life (cycles)	100,000
Operating Temperature Range	-20° ~ +70° C
Storage Temperature Range	-40° ~ +85° C

RoHS Compliant

TOLERANCES ARE

**MORETHANALL**  
PCB CONNECTORS  
Cable ASSEMBLIES

煜倫股份有限公司

www.morethanall.com

DRAWING BY CY

CHECKED BY GENIUS

UNIT / mm

SCALE 1 : 1

DATE

SIZE A4

PJECTION

Up to 5 ±0.2  
Above 5 ~ 15 ±0.3  
Above 15 ~ 30 ±0.4  
Above 30 ~ 50 ±0.5  
Angle ±0.3°

照片框

ORDER INFORMATION

TSW36-WFR-xxx-LF

SERIES LEADFREE  
160:160g  
250:250g  
REEL  
OFF SET  
90°SMT

DESCRIPTION: SWITCH

