

N = Number of poles  
 Dim.L =  $N \times 3.5 + 0.35$   
 Dim.P =  $(N - 1) \times 3.5$

Poles	Dim.L	Dim.P
2-6p	$\pm 0.25$	$\pm 0.20$
7-12p	$\pm 0.30$	$\pm 0.25$
13-16p	$\pm 0.35$	$\pm 0.30$

Materials

- ⚠ Item ① Terminal body: High temp. polyamide (UL94V-0)
- Item ② Terminal screw: Steel Zinc plating "+/-" slot type
- Item ③ Wire guard: Stainless steel
- Item ④ Terminal: Brass (CuZn) Tin Plated
- Item ⑤ Terminal Cover: High temp. polyamide (UL94V-0)

Electrical UL

- Voltage rating: 150VAC
- Current rating: 10A
- Wire range:
- Solid wire (AWG): 16-26
- Stranded wire (AWG): 16-26
- Torque (Lb-In): 2.0
- Screw: M2.0
- Wire strip length: 5-6mm
- Withstanding Voltage: 1.6KV
- ⚠ Operating temperature: -45°C to +65°C
- Soldering temperature: 280°C/10 Sec
- Safety Approval:
- Critical dimension: ▽

RoHS Compliant

TOLERANCES ARE

**MORETHANALL**  
 PCB CONNECTORS  
 Cable ASSEMBLIES

煜倫股份有限公司

www.morethanall.com

DRAWING BY CY

CHECKED BY GENIUS

UNIT / mm

SCALE 1 : 1

DATE

SIZE A4

X, ± 0.50

.X, ± 0.30

.XX, ± 0.10

.XXX, ±

ANG ± 1°

P PROJECTION

照片框

ORDER INFORMATION

TBN035-V11XCR-xx-LF

SERIES | | | | LEADFREE  
 | | | | REEL  
 | | | | CAP  
 180°SMT | | | | NON POST  
 | | | | HIGH 10.6mm

DESCRIPTION:

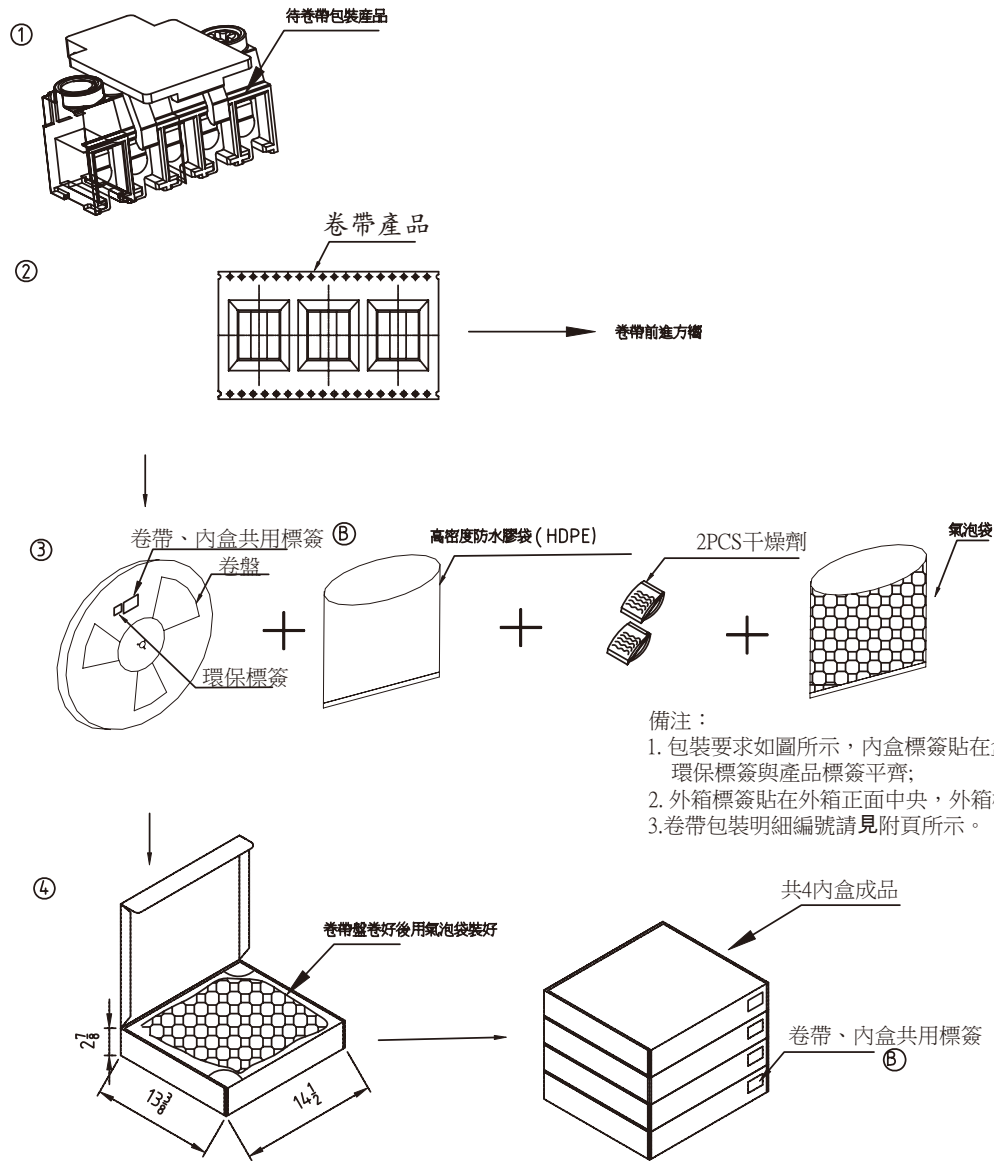

備注：  
 1. 包裝要求如圖所示，內盒標籤貼在盒蓋正側下角邊，環保標籤與產品標籤平齊；  
 2. 外箱標籤貼在外箱正面中央，外箱標籤只貼一面（如圖所示）；  
 3. 卷帶包裝明細編號請見附頁所示。

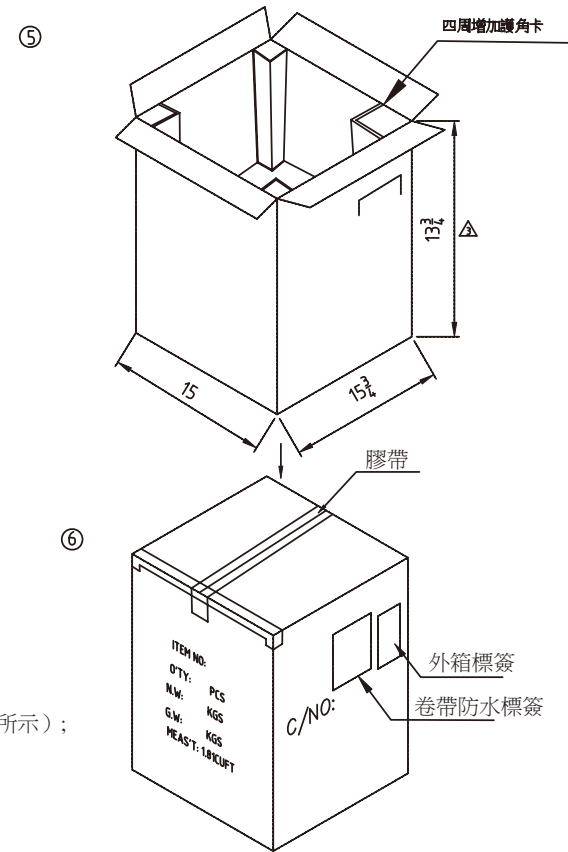

RoHS Compliant

TOLERANCES ARE

**MORETHANALL**  
 PCB CONNECTORS  
 Cable ASSEMBLIES  
**煜倫股份有限公司**  
 www.morethanall.com

DRAWING BY CY  
 CHECKED BY GENIUS  
 UNIT / mm SCALE 1 : 1  
 DATE  
 SIZE A4 PPROJECTION

X. ± 0.50  
 .X ± 0.30  
 .XX ± 0.10  
 .XXX ±  
 ANG ± 1°

照片框

ORDER INFORMATION

TBN035-V11XCR-xx-LF  
 SERIES | | | | LEADFREE  
 | | | | 02~16WAY  
 | | | | REEL  
 | | | | CAP  
 180°SMT | | | | NON POST  
 | | | | HIGH 10.6mm

DESCRIPTION: