

N = Number of contacts

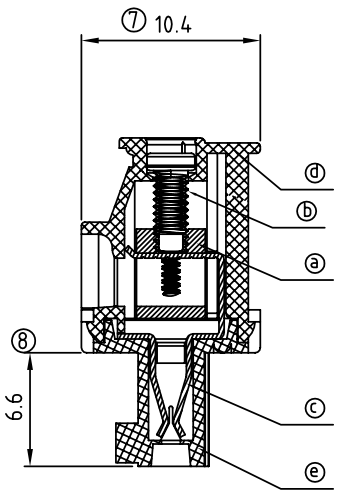

Material

- Item a Terminal body(metal housing): Brass(CuZn),Nickel plated
 - Item b Terminal screw: Steel Zinc plating "-" slot type
 - Item c Wire guard: PhBz, Tin plated
 - Item d Insulator (housing): Thermoplastic (UL94V-0)
 - Item e Insulator (cover): Thermoplastic (UL94V-0)
 - Item f Wire flange screw: Steel M2.5 Zinc plating "+/-" slot type
- Electric ULus/VDE
- Voltage Rating: 300VAC/300VAC
 - Current rating: 8A/8A
 - Wire range: 1.5mm
 - Solid wire(AWG): 16-28²
 - Stranded wire(AWG): 16-28
 - Torque: 1.7Lb-In./0.2Nm
 - Screw: M2
 - Wire strip length: 6-7mm
 - Withstanding Voltage: 1.6KV/2.5KV
 - Operating temperature: -40°C to +115°C
 - Safety approval:

TBH035-SVCAF-xx-LF
LEADFREE
RoHS Compliant

Poles	Tolerance
2P-8P	±0.10
9P-16P	±0.20
17P-24P	±0.30

DIMENSION

A	NX3.5
B	(N-1)X3.5



PART NO. TBH035-SVCAF-xx		CHECKED BY CY		TOLERANCES ARE .X ± 0.2 .XX ± .XXX ± AWG		DESCRIP TION:				
DWG NO. TBH035-SVCAF-xx		DRAWING BY								
FILE NO.		PROJECTION		AREA	REVISIONS	HK	DATE			
UNIT / mm	SCALE 1:1									

煜倫股份有限公司