

PCB LAYOUT

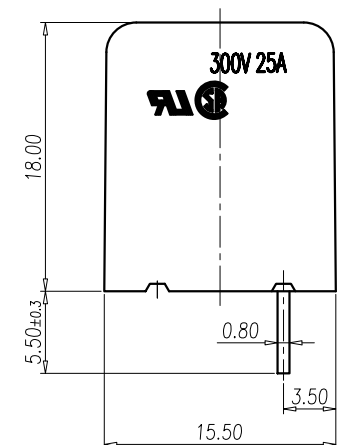
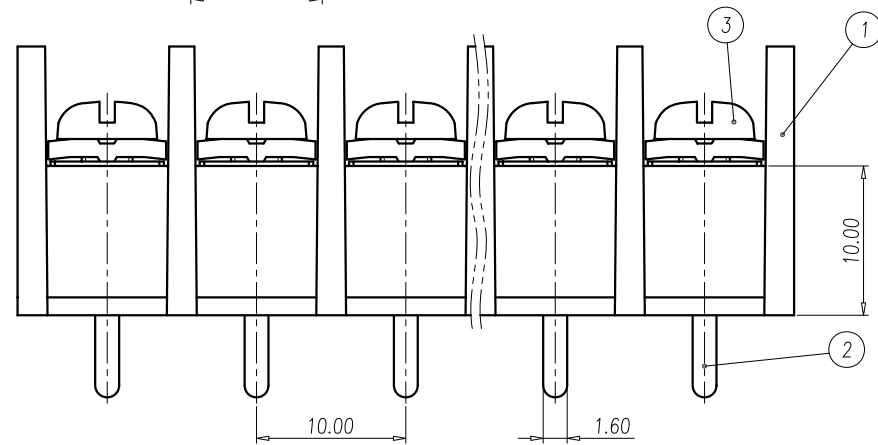

NOTES 1:

- UL Standard :
- 1.Rating: 300V 25A
 - 2.Insulation Withstands Voltage: AC 2000 V at 1 minute
 - 3.Using Temperature Range: -40°C~+115°C
 - 4.Screw Torque Value:1.0N·m
 - 5.Suitable Electric Wire:AWG 22~12

IEC Standard:

1. Rate Impulse Voltage: 6000V
- 2.Insulation Resistance: 500M Ω or more at DC500V

NOTES 2:

1. RoHS compliance

Normal Geometric Tolerancing			
—	//	\equiv	\perp
0 to 100	0.2	0.3	0 to 10
over 100 to 150	0.3		over 10
over 150	0.5		0.3
Total Pitch Tolerances		Normal Dimension Tolerances	
0~30	±0.20	0~30	±0.25
over 30~53	±0.25	over 30~53	±0.30
over 53~70	±0.30	over 53~70	±0.35
over 70~90	±0.35	over 70~90	±0.44
over 90~115	±0.44	over 90~115	±0.55
over 115~150	±0.55	over 115~150	±0.70
over 150~200	±0.70	over 150~200	±0.85
over 200~250	±0.85	over 200~250	±1.00
over 250~320	±1.00	over 250~320	±1.20

P	2	3	4	5	6	7	8	9	10	11	12	13	14	15	16
U	10.0	20.0	30.0	40.0	50.0	60.0	70.0	80.0	90.0	100.0	110.0	120.0	130.0	140.0	150.0
V	22.0	32.0	42.0	52.0	62.0	72.0	82.0	92.0	102.0	112.0	122.0	132.0	142.0	152.0	162.0
P	17	18	19	20	21	22	23	24	25	26	27	28	29	30	
U	160.0	170.0	180.0	190.0	200.0	210.0	220.0	230.0	240.0	250.0	260.0	270.0	280.0	290.0	
V	172.0	182.0	192.0	202.0	212.0	222.0	232.0	242.0	252.0	262.0	272.0	282.0	292.0	302.0	

ITEM	NAME OF PART	MATERIAL	NOTES
3	SCREW	STEEL	M3.5/Ni Plated
2	SOLDER PIN	COPPER ALLOY	Tin Plated
1	HOUSING	PA	UL94-V0 BLACK

RoHS Compliant

TOLERANCES ARE

MORETHANALL
PCB CONNECTORS
Cable ASSEMBLIES

煜倫股份有限公司

www.morethanall.com

DRAWING BY CY

CHECKED BY GENIUS

UNIT / mm SCALE 1 : 1

DATE

SIZE A4

X, ±
.X ±
.XX ±
.XXX ±
ANG ±

PJECTION

照片框

ORDER INFORMATION

TBB100-DS-xx-LF

SERIES

LEADFREE

02~30WAY

SIDE PIN

DIP 180°

DESCRIPTION: