

SPECIFICATIONS

- ① Housing Material: Polyamide 66(UL94V2), Black
- ② Screw: M3.0 Nickel Plated Steel
- ③ Terminals: Tin Plated Brass
- ④ Cover: PC Transparent

Screws Torque: 7 In-Lb

Wier Range: 16~22 AWG

Rated: 10 Amperes.AC250V

Pperation Temperature: -55°C~+100°C

Insulation withstands volt: AC2000V min

Insulation resistance: >1000Ω or more at DC500V

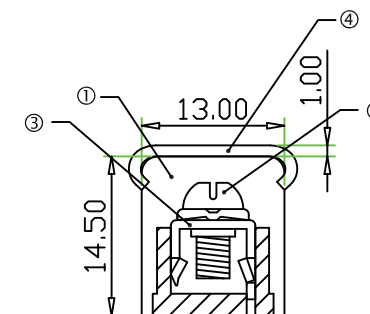
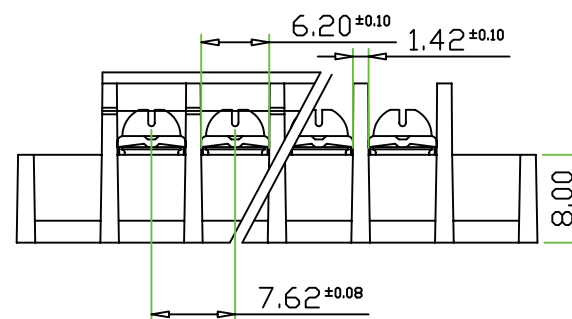
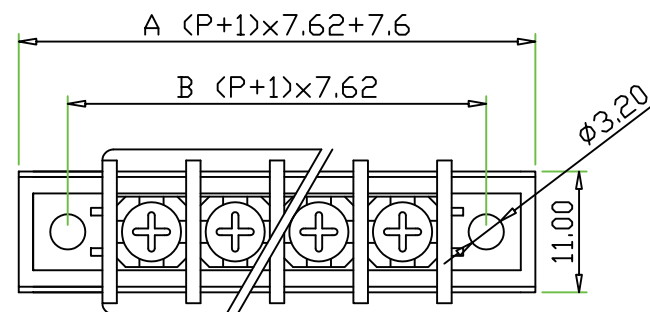

Tolerance ± 0.5

POLE	2	3	4	5	6	7	8	9	10	11	12	13	14	15	
A	30.46	38.08	45.7	53.32	60.94	68.56	76.18	83.8	91.42	99.04	106.66	114.28	121.9	129.52	
B	22.86	30.48	38.1	45.72	53.34	60.96	68.58	76.2	83.82	91.44	99.06	106.68	114.3	121.92	
POLE	16	17	18	19	20	21	22	23	24	25	26	27	28	29	30
A	137.14	144.76	152.38	160	167.62	175.24	182.86	190.48	198.1	205.72	213.34	220.96	228.58	236.2	243.82
B	129.54	137.16	144.78	152.4	160.02	167.64	175.26	182.88	190.5	198.12	205.74	213.36	220.98	228.6	236.22

RoHS Compliant

TOLERANCES ARE

MORETHANALL
PCB CONNECTORS
Cable ASSEMBLIES

煜倫股份有限公司

www.morethanall.com

DRAWING BY CY

CHECKED BY GENIUS

UNIT / mm SCALE 1 : 1

DATE

SIZE A4

X, ±
.X ±
.XX ±
.XXX ±
ANG ±

PJECTION

照片框

ORDER INFORMATION

TBB076-DEC-xx-LF

SERIES | LEADFREE
| 02~30WAY
| CAP
| EAR
| DIP 180°

DESCRIPTION: