

SCHEMATIC

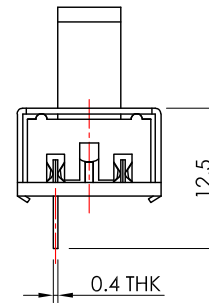
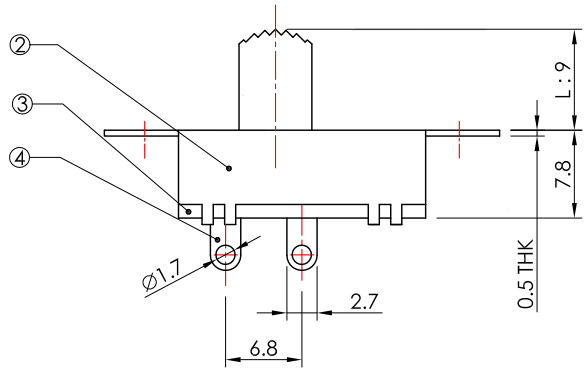
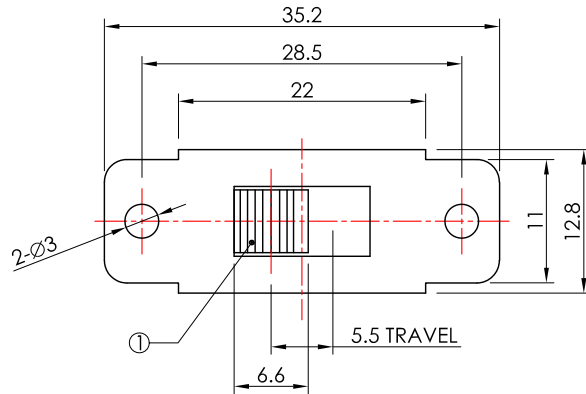
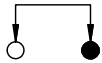

SPECIFICATION

Rating: 3A 250V AC / 6A 125V AC.

Circuit: SPST.

Timing: Non-Shorting.

Contact resistance: 120mΩ Max.

Insulation resistance: 100MΩ Min. at 500V DC.

Withstand voltage: 500V AC for 1 minute.

Operating force: 300±100g.

Life: 10,000 Cycles.

Soldering temperature: 230±5°C for 3±0.5 seconds.

Soldering time: 1 time only.

Note1: Unwashable, don't be immersed by epoxy and organic solvent.

Note2: Please do not scale the drawing comparing to real product and kindly measure the size of real product.

MATERIAL

Knob: PC, black.

Frame: Steel strip, Ni plated.

Base: Phenolic resin, natural.

Terminal: Brass strip, Ag plated.

Spring: Steel wire, natural.

Steel ball: Steel, natural.

Position plate: Steel strip, Ni plated.

Contact clip: PBS strip, Ag plated.

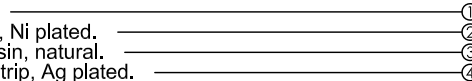

保存注意事項：

Precautions for preservation:

1. 此產品為鍍銀或鍍金產品，裸露在空氣中極易氧化，會造成冷焊或焊接不良。

建議拆封後，未使用完的開關務必放入袋內，並置入乾燥劑後密封袋口，以防氧化。

This is a silver-plated or gold-plated product, which can be easily oxidized when exposed to air that may cause cold welding or poor welding.

We recommend that after unpacking, the unused switch must be preserved into a sealed bag with desiccant to prevent oxidation.

2. 若產品拆封後，客戶未盡妥善保存之責，造成產品氧化，我司無法負保固責任。

After the product is unpacked, if the customer fails to properly preserve the product, causing the product to oxidize, our company cannot be held responsible for the warranty.

RoHS Compliant

TOLERANCES ARE



煜倫股份有限公司

www.morethanall.com

DRAWING BY CY

CHECKED BY GENIUS

UNIT / mm

SCALE 1 : 1

DATE

SIZE A4

X, ±
.X ± 0.30
.XX ± 0.20
.XXX ±
ANG ±

PJECTION

照片框

ORDER INFORMATION

SLSW68-SPE090-1X02-LF

SERIES

LEADFREE

02 WAY

9.0mm KNOB HEIGHT

PANEL
SOLDER

DESCRIPTION: