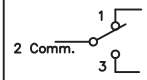
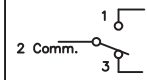

Model No.	POS.1	POS.2	POS.3
	5MS1	ON	NONE
Term. Comm.	2-1	N/A	2-3
SCHEMATIC			

SWITCH FUNCTION

SPECIFICATIONS

- MECHANICAL LIFE:** 30,000 make-and-break cycles.
- CONTACT RESISTANCE:** 10 mΩ max. initial @ 2-4VDC
100mA for both silver and gold plated contacts.
- INSULATION RESISTANCE:** 1,000 MΩ min.
- DIELECTRIC STRENGTH:** 1,000 Vrms min. @ sea level.
- OPERATING TEMPERATURE:** -30°C to 85°C.

MATERIALS

- CASE:** Diallyl phthalate (DAP) (UL94v-0).
- ACTUATOR:** Nylon, black std.
- HOUSING:** Stainless Steel.
- CONTACT:** Brass, with Silver or gold plated.
- TERMINAL SEAL:** EPOXY
- RoHS:** 2002/95/EC

RoHS Compliant

TOLERANCES ARE



煜倫股份有限公司

www.morethanall.com

DRAWING BY CY		X ±
CHECKED BY GENIUS		.X ± 0.40
UNIT / mm	SCALE 1 : 1	.XX ± 0.25
DATE		.XXX ±
SIZE A4	PJECTION	ANG ± 5°



ORDER INFORMATION

SLSW47-DZ119-1X03-LF
 SERIES | LEADFREE
 03 WAY
 KNOB LENGTH 11.96mm
 CLIP
 DIP 180°

DESCRIPTION: Slide Switches