

| NO | 品名 NAME | 材質 MATL | 件數 SHT | 處理 TREAT | NO | 品名 NAME | 材質 MATL | 件數 SHT | 處理 TREAT |
|----|---------|----------|--------|----------|----|---------|----------|--------|----------|
| 1 | 本體 | Zn ALLOY | 1 | M-Cr | 7 | 電木蓋 | BAKELITE | 1 | —— |
| 2 | 半月邊 | Zn ALLOY | 1 | M-Cr | 8 | 扣環 | SUS | 1 | —— |
| 3 | 固定帽 | Zn ALLOY | 1 | M-Cr | 9 | 橡膠套 | RUBBER | 1 | —— |
| 4 | 齒型座 | Zn ALLOY | 1 | M-Cr | 10 | 圓頭十字螺釘 | IRON | 2 | M-Ni |
| 5 | 導梢 | BRASS | 3 | M-Au | 11 | 側螺絲 | BsBM | 1 | M-Ni |
| 6 | 電木座 | BAKELITE | 1 | —— | | | | | |

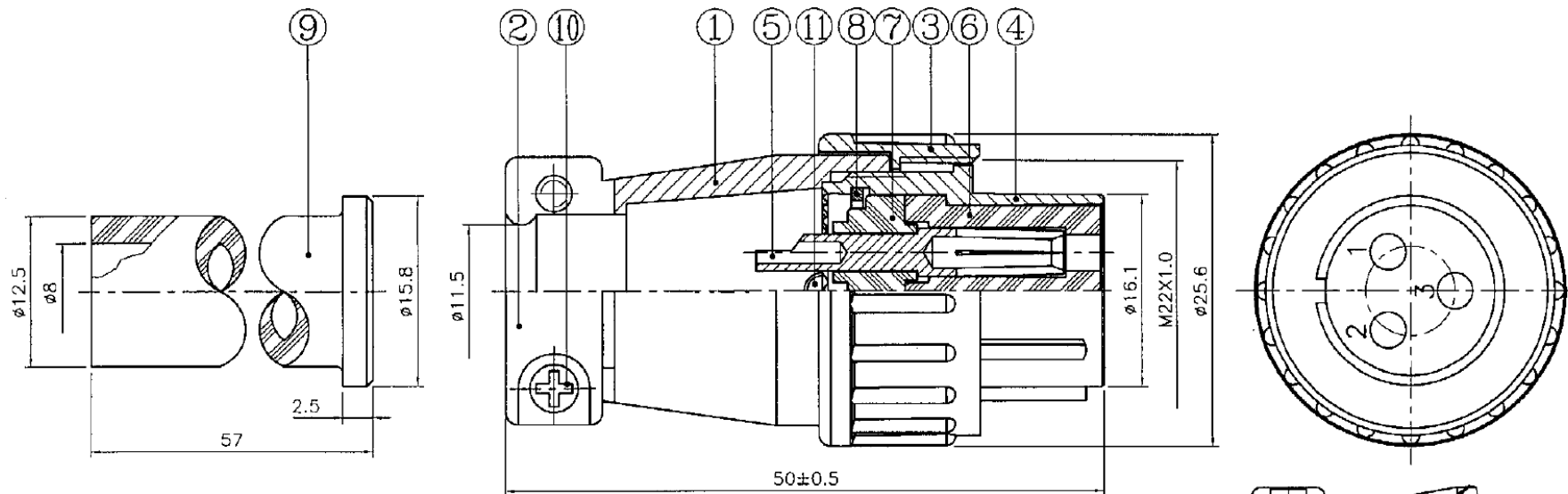

| NO. | ELECTRICAL CHARACTERISTICS | |
|-----|---|----------|
| 1 | Rated Current/voltage | 15A 250V |
| 2 | Operation limit voltage (AC.V.rms) | 250 |
| 3 | Withstanding voltage (AC.V.rms) 1 minute | 1500 |
| 4 | Insulation resistance(MΩ MIN.) at DC 500V | 2000 |
| 5 | Contact resistance (mΩ MAX.) at DC 1A | 3 |
| 6 | Pin diameter (φmm) | 1.8 |

後視圖

SCALE 1.5X

RoHS Compliant

TOLERANCES ARE

MORETHANALL
PCB CONNECTORS
Cable ASSEMBLIES

DRAWING BY CY

X.±

CHECKED BY GENIUS

.X±

UNIT/mm

SCALE 1:1

.XX±

DATE

.XXX±

ANG±

SIZE A4

PJECTION

照片框

ORDER INFORMATION

SLM22-SA-03-LF

SERIES LEADFREE
03 WAY
ASSEMBLY
FEMALE

煜倫股份有限公司

www.morethanall.com

DESCRIPTION: