

NOTES.

- 1. 材質: ハウジング: LCP樹脂, UL94V-0, 色: 黒色
 コンタクト: 銅合金
 メタルラッチ: ステンレス
 MATERIAL: HOUSING: LCP, UL94V-0, COLOR: BLACK
 CONTACT: COPPER ALLOY
 METAL LATCH: SUS
- △ メッキ: コンタクト (接点部, 半田付け部); 金メッキ 0.0075μmMIN, ニッケル下地 1.5μmMIN.
 PLATING: CONTACT (CONTACT POINT, SOLDER AREA):
 Au PLATE 0.0075μm MIN, Ni UNDER PLATE 1.5μm MIN.
- △ コネクタを平坦面に置き、端子半田付け部の浮きは、0.1mm以下
 MUST BE MEASURED FLOATING AMOUNT OF CONTACT TAILS
 FROM DATAM SURFACE IS 0.1mm MAX.

- △ 倍率適用外寸法
 NOT TO SCALE.
- △ 公差非累積
 TOLERANCES NON-CUMULATIVE
- △ 他社のソケット用
 FOR SOCKET OF THE OTHER COMPANIES

RoHS Compliant

TOLERANCES ARE

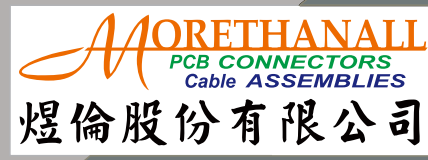

DRAWING BY CY
 CHECKED BY GENIUS
 UNIT / mm SCALE 1 : 1
 DATE

X, ±
 .X ± 0.20
 .XX ±
 .XXX ±
 ANG ± 3°

SIZE A4 PROJECTION

照片框

ORDER INFORMATION

SDM6-W52V15-A372-LF
 SERIES | | LEADFREE
 | | 204 WAY
 | | 1.5V
 | | HIGH 5.2mm
 90°SMT

DESCRIPTION: FOR 204PIN DDR S.O DIMM(DDR3)

www.morethanall.com

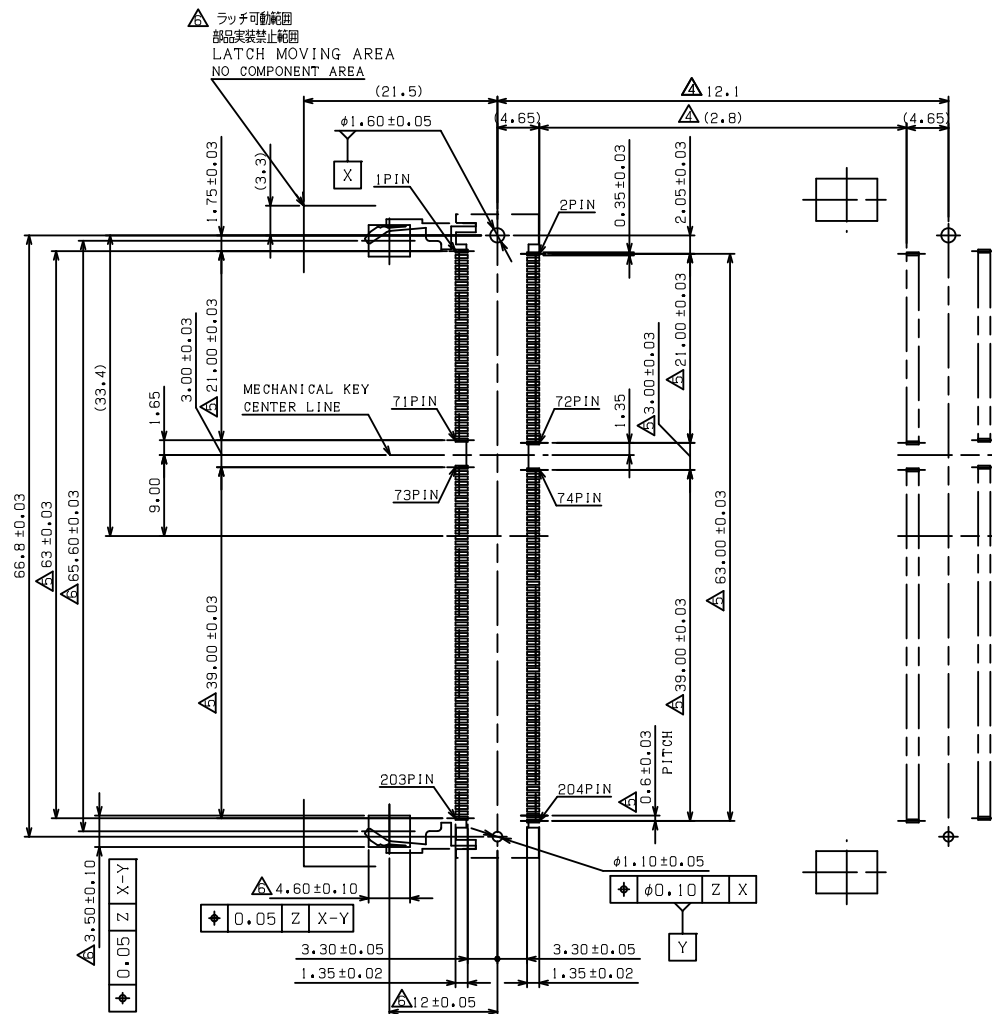

推奨基板レイアウト寸法
RECOMMENDED MOUNTING
P.C. BOARD PATTERN LAYOUT DIM.

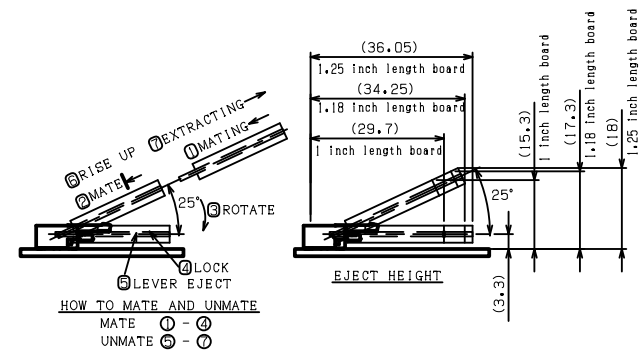

MORETHANALL
PCB CONNECTORS
Cable ASSEMBLIES

煜倫股份有限公司

www.morethanall.com

RoHS Compliant

DRAWING BY CY

CHECKED BY GENIUS

UNIT / mm

SCALE 1 : 1

DATE

SIZE A4

TOLERANCES ARE

X, ±
X ± 0.20
.XX ±
.XXX ±
ANG ± 3°

P PROJECTION

照片框

ORDER INFORMATION

SDM6-W52V15-A372-LF

SERIES

|

|

|

|

|

|

|

|

|

|

|

|

|

|

|

LEADFREE
204 WAY

1.5V
HIGH 5.2mm
90°SMT

DESCRIPTION: FOR 204PIN DDR S.O DIMM(DDR3)

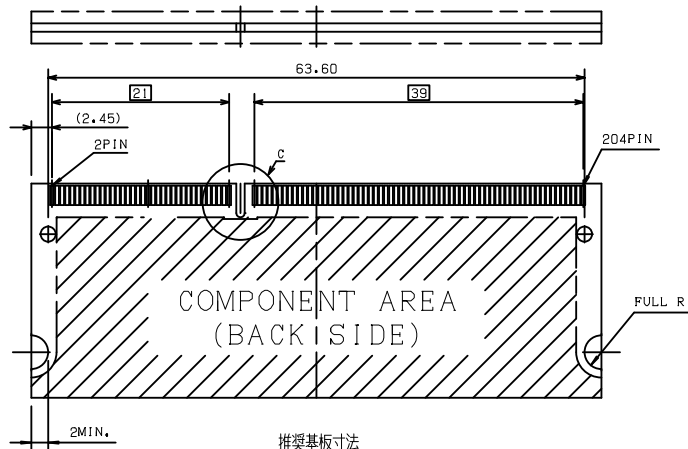
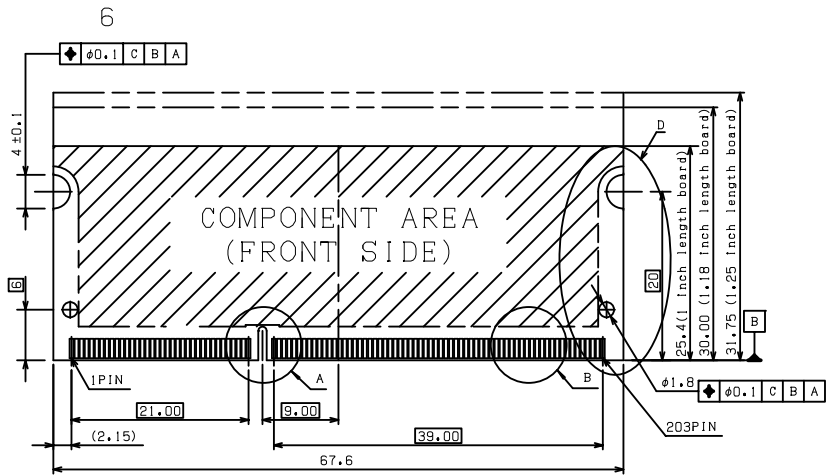

推奨基板寸法
RECOMMENDED MATING
P.C. BOARD DIM.

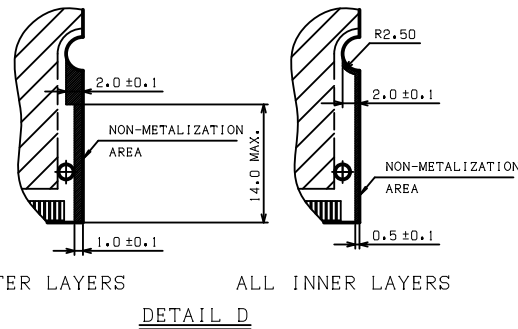
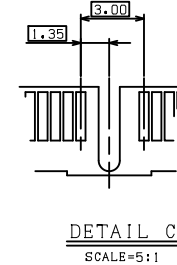
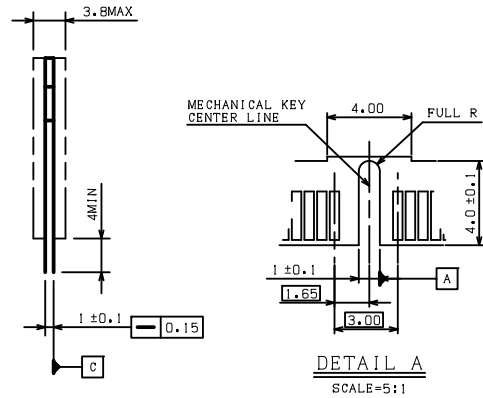
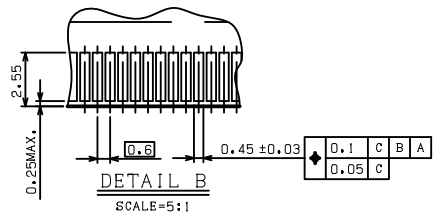

注記: (SHEET 3 に適用)
NOTES: (APPLIED TO SHEET 3)
1. 一般公差 ± 0.15
TOLERANCES ON ALL DIMENSION ± 0.15 UNLESS OTHERWISE SPECIFIED.
2. 基板厚寸法は、メッキ厚を含む。
P.C. BOARD THICKNESS APPLIES ACROSS TABS AND INCLUDES PLATING AND/OR METALIZATION.
3. パット部の仕上げ: ニッケルが下地メッキ 0.002MIN, 厚の比、金メッキ 0.000756MIN, 厚を施す。
FINISH OF PAD: GOLD PLATING 0.00076MIN, OVER NI PLATING 0.002MIN.

MORETHANALL
PCB CONNECTORS
Cable ASSEMBLIES
煜倫股份有限公司
www.morethanall.com

DRAWING BY CY		TOLERANCES ARE X, ± .X ± 0.20 .XX ± .XXX ± ANG ± 3°
CHECKED BY GENIUS		
UNIT / mm	SCALE 1 : 1	
DATE		
SIZE A4	P PROJECTION	

照片框

ORDER INFORMATION		
SDM6-W52V15-A372-LF		
SERIES	1.5V	LEADFREE
	HIGH 5.2mm	204 WAY
	90°SMT	
DESCRIPTION: FOR 204PIN DDR S.O DIMM(DDR3)		

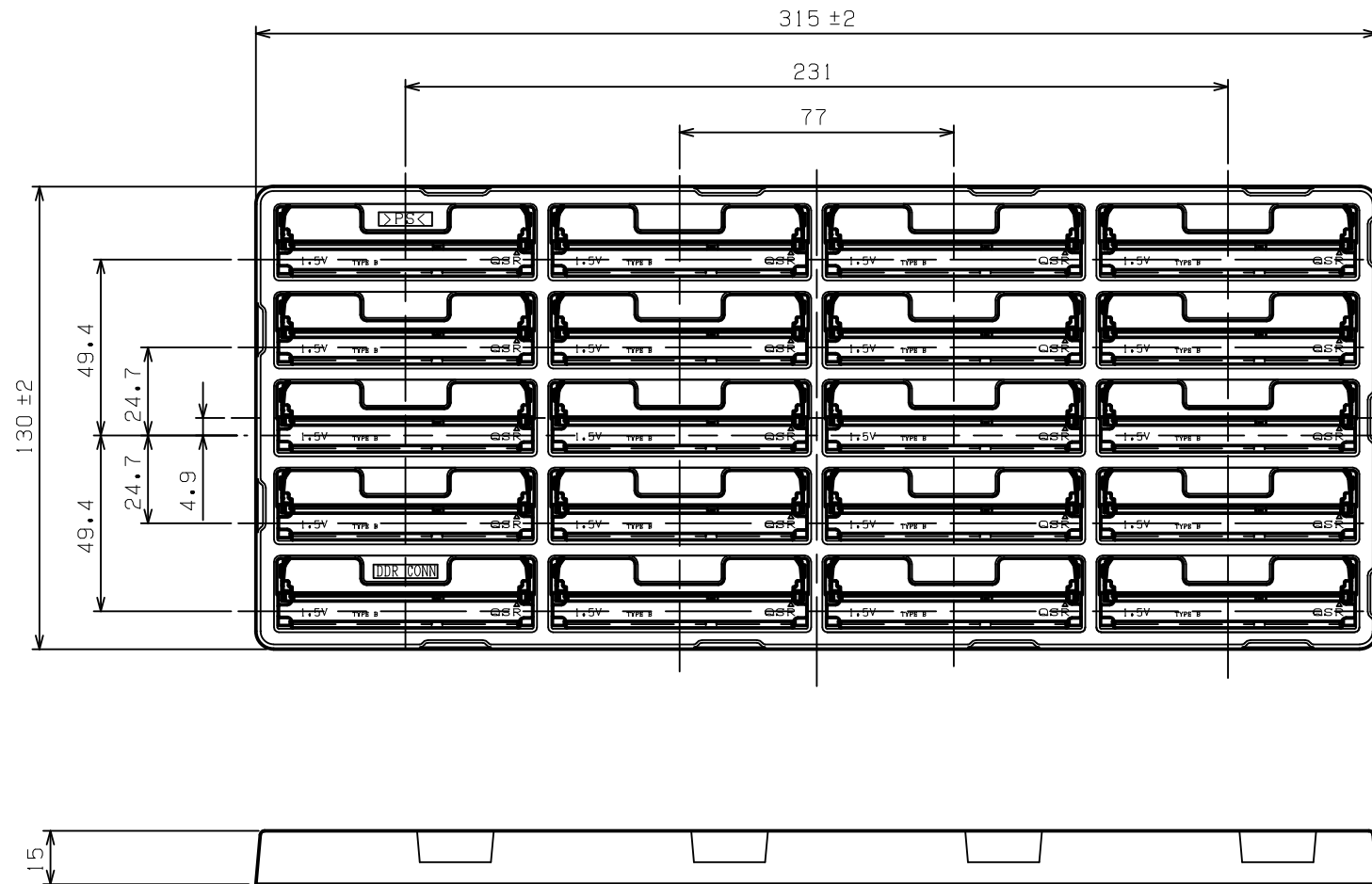

® SOFT TRAY PACKAGING

MORETHANALL
PCB CONNECTORS
Cable ASSEMBLIES

煜倫股份有限公司

www.morethanall.com

RoHS Compliant

DRAWING BY CY
CHECKED BY GENIUS
UNIT / mm SCALE 1 : 1
DATE
SIZE A4

TOLERANCES ARE

X, ±
.X ± 0.20
.XX ±
.XXX ±
ANG ± 3°

PJECTION

照片框

ORDER INFORMATION

SDM6-W52V15-A372-LF
SERIES | 1.5V | 204 WAY | LEADFREE
HIGH 5.2mm
90°SMT

DESCRIPTION: