

NOTES:

1. SPECIFICATIONS: (OPTION)

ELECTRICAL:

RATING CURRENT: 0.5 A
 INSULATION RESISTANCE: 1000MΩ Min. at 100V DC
 CONTACT RESISTANCE: 100 mΩ Max.
 WITHSTANDING VOLTAGE: 500V AC

MECHANICAL:

CONTACT RETENTION Force: 0.25kgf MIN.
 INSERTION FORCE: 4.2kgf MAX.
 WITHDRAWAL FORCE: 0.21kgf MIN.
 Durability:10,000 times

ITEM 項目	PARTS NAME 零件名稱	MATERIAL 材質	FINISH/REMARK 處理/備註
A	HOUSING	SYNTHETIC RESIN	BLACK
B	SHELL	STAINLESS T=0.2	NON-PLATING
C	HOLDDOWN CONTACT	COPPER ALLOY T=0.20	80u"MIN. TIN PLATING ON SOLDER TAIL AREA 30u"MIN. NICKEL UPDERPLATING OVERALL
D	CAM PIN	STAINLESS Ø0.4	NON-PLATING
E	CARD LOCK	STAINLESS T=0.20	NON-PLATING
F	SLIDER CAM	SYNTHETIC RESIN	BLACK
G	SPRING	SWP Ø0.25	50u"MIN. NICKEL UPDERPLATING OVERALL
H	CONTACT-SD	COPPER ALLOY T=0.15	5u"MIN. GOLD PLATING ON CONTACT AREA 80u"MIN. TIN PLATING 30u"MIN. NICKEL UPDERPLATING OVERALL
I	PROTECT CONTACT		
J	PROTECT CONTACT AND DETECT CONTACT-SWITCH		
K	DETECT CONTACT		
L	假卡	SYNTHETIC RESIN	BLACK

- WHEN DELIVERING, THE PSH/PUSH MECHANISM IS IN THE STATE OF THE UNLOCK.
(CARD DASHING OUT POSITION)
- CARD READ ONLY BY THE TIME THE CARD DETECTION SWITCH WORKS.
- OPEN AND CLOSE OF EACH SWITCH.

CARD INSERTION STATUS	WRITE PROTECT SWITCH		DETECT SWITCH
	WRITE PROTECT POSITION	WRITE ENABLE POSITION	
CARD UNINSERTION	OPEN	OPEN	OPEN
CARD HALF INSERTION	COLSE	COLSE	OPEN
CARD INSERTION	OPEN	COLSE	COLSE

RoHS Compliant

TOLERANCES ARE

MORETHANALL
 PCB CONNECTORS
 Cable ASSEMBLIES

DRAWING BY CY

X. ± 0.50

CHECKED BY GENIUS

.X ± 0.30

UNIT / mm

SCALE 1 : 1

.XXX ±

ANG ± 5°

DATE

SIZE A4

PJECTION

照片框

ORDER INFORMATION

SDC-W26PA22R-09-LF

SERIES | | | | | LEADFREE
 | | | | | 09 WAY
 REEL
 90°SMT | | | | | PAD 2+2mm
 POST 26.20mm | | | | | UPPER CONTACT
 | | | | | PUSH PUSH

煜倫股份有限公司

www.morethanall.com

DESCRIPTION: SD MEMORY CARD CONN
 REVERSE TYPE WITH PUSH PUSH (FOR MOLEX SD-67913-001)加長版

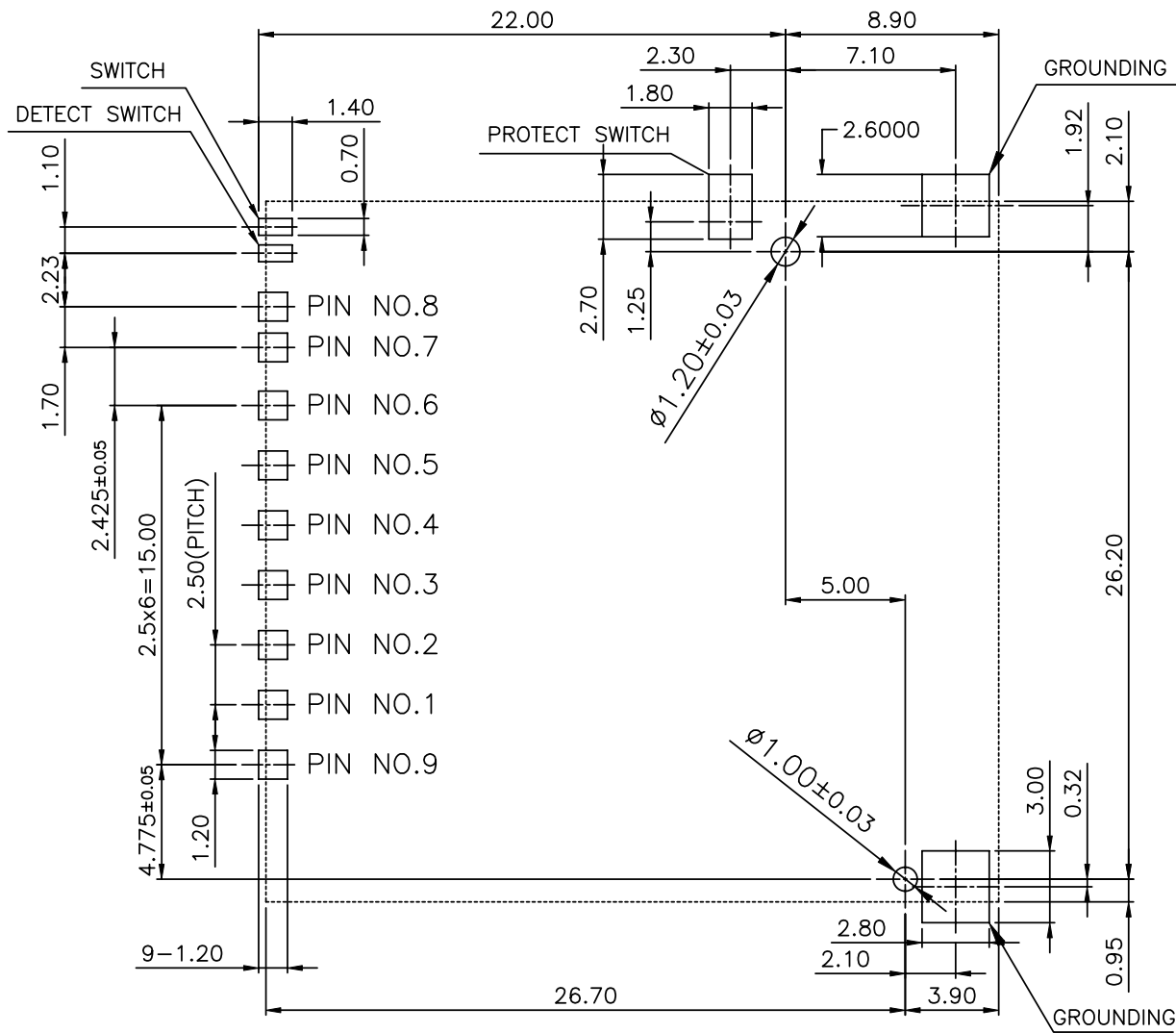

PIN DEFINE

PAD NO.	MEMORY CARD
SD-01	SD-CD/DAT3
SD-02	SD-CMD
SD-03	SD-VSS
SD-04	SD-VDD
SD-05	SD-CLK
SD-06	SD-VSS
SD-07	SD-DAT0
SD-08	SD-DAT1
SD-09	SD-DAT2

PCB TOLERANCE:±0.05

RoHS Compliant

TOLERANCES ARE



煜倫股份有限公司

www.morethanall.com

DRAWING BY CY

CHECKED BY GENIUS

UNIT / mm

SCALE 1 : 1

DATE

SIZE A4

X ± 0.20

.X ± 0.10

.XX ± 0.05

.XXX ±

ANG ± 5°

P PROJECTION

照片框

ORDER INFORMATION

SDC-W26PA22R-09-LF

SERIES | | | | | LEADFREE
 | | | | | 09 WAY
 REEL
 90°SMT | | | | | PAD 2+2mm
 POST 26.20mm | | | | | UPPER CONTACT
 PUSH PUSH

DESCRIPTION: RECOMMENDED PCB LAYOUT

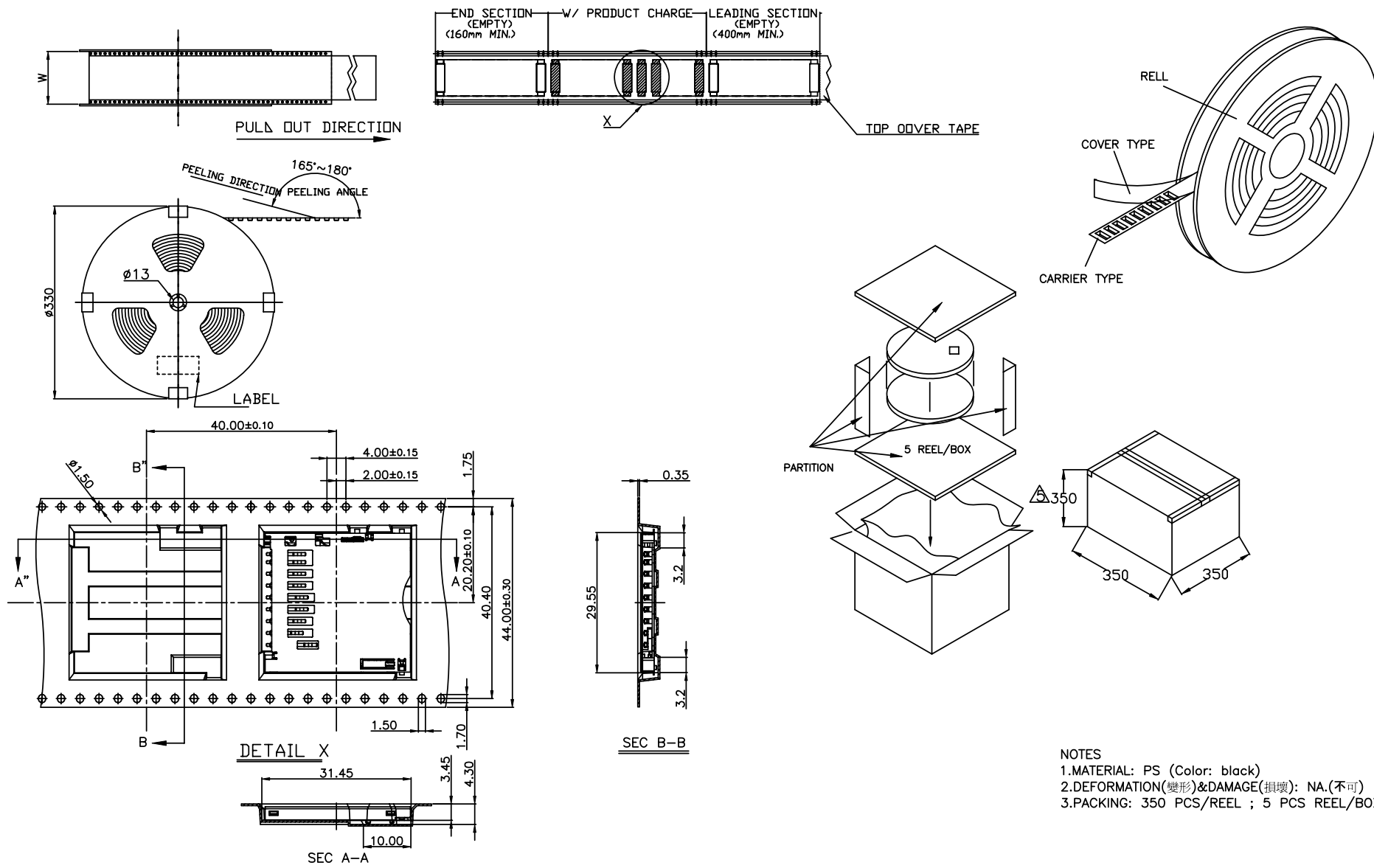

- NOTES
- 1.MATERIAL: PS (Color: black)
 - 2.DEFORMATION(變形)&DAMAGE(損壞): NA.(不可)
 - 3.PACKING: 350 PCS/REEL ; 5 PCS REEL/BOX

RoHS Compliant

TOLERANCES ARE

MORETHANALL
PCB CONNECTORS
Cable ASSEMBLIES

煜倫股份有限公司

www.morethanall.com

DRAWING BY CY

CHECKED BY GENIUS

UNIT / mm

SCALE 1 : 1

DATE

SIZE A4

X. ± 0.40

.X ± 0.25

.XX ± 0.10

.XXX ±

ANG ± 2°

PJECTION

照片框

ORDER INFORMATION

SDC-W26PA22R-09-LF

SERIES | | | | | LEADFREE
| | | | | 09 WAY
| | | | | REEL
90°SMT | | | | | PAD 2+2mm
POST 26.20mm | | | | | UPPER CONTACT
| | | | | PUSH PUSH

DESCRIPTION: Packing Drawing