

6	SD板下沉板下外觀	SUS304	1
5	SD拉桿	SWP	1
4	SD機構	LCP	1
3	SD板下沉板下彈簧	SUS	1
2	SD板下沉板下端子	C2680-SH	1
1	SD板下主體	LCP	1
ITEM	Title	Material	Pcs

RoHS Compliant

TOLERANCES ARE

MORETHANALL
PCB CONNECTORS
Cable ASSEMBLIES

煜倫股份有限公司

www.morethanall.com

DRAWING BY CY

CHECKED BY GENIUS

UNIT / mm SCALE 1 : 1

DATE

SIZE A4

X, ±
X ± 0.38
.XX ± 0.25
.XXX ± 0.10
ANG ±

PPOJECTION

照片框

ORDER INFORMATION

SDC-W26PA190R-09-LF

SERIES | | | | | LEADFREE
09 WAY

REEL
90°SMT PAD TO POST 19.25mm
POST 26.40mm UPPER CONTACT
PUSH PUSH

DESCRIPTION:

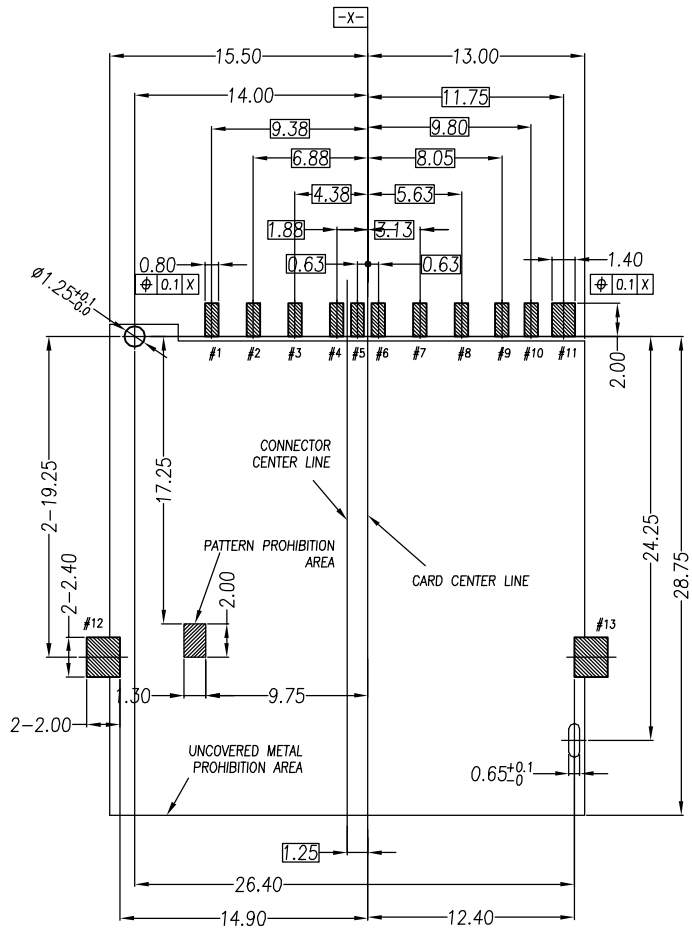

RECOMMEND P.C.B LAYOUT
TOLERANCE ± 0.05

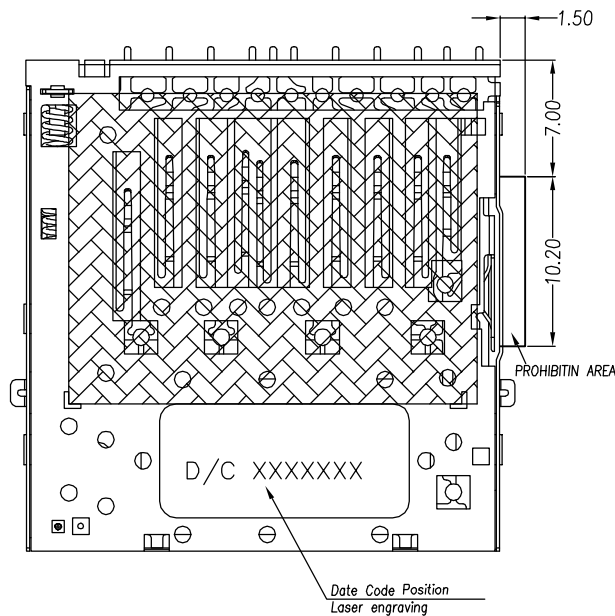

WITHOUT CARD		CARD INSERTED: LOCK		CARD INSERTED: UNLOCK	
W/P #11	GND #12	W/P #11	GND #12	W/P #11	GND #12
C/D #04	VSS1 #05	C/D #04	VSS1 #05	C/D #04	VSS1 #05

Specification

*Electrical Characteristics:

Contact Current Rating: 0.5 Amperes.
Dielectric Withstanding Voltage: AC500V r.m.s.
Insulation Resistance: 1000 M Ω Minimum.
Contact Resistance: 100 m Ω Maximum.

*Environmental:

Operating Temperature: $-25^{\circ}\text{C} \sim +85^{\circ}\text{C}$.

*Mechanical Characteristics:

Mating Cycles: 10,000 Cycles Insertion/Extraction
Card Push Insertion/Out Force: 1kgf Maximum.
Contact Retention Force: 0.15kgf Minimum.

*Material:

Insulator: HI-Temp Plastic UL 94V-0 Rated.
Contact: Copper Alloy.
Shell: Stainless Steel.
Spring: SWPB.

Pin Define

Connector Pin No.	SD Card Pin No.	Pin Define
P1	P9	DAT2
P2	P1	DAT3
P3	P2	CMD
P4		CD
P5	P3	VSS1
P6	P4	VDD
P7	P5	CLK
P8	P6	VSS2
P9	P7	DAT0
P10	P8	DAT1
P11		W/P
P12		GND
P13		GND

RoHS Compliant

TOLERANCES ARE

MORETHANALL
PCB CONNECTORS
Cable ASSEMBLIES

DRAWING BY CY

CHECKED BY GENIUS

UNIT / mm SCALE 1 : 1

DATE

SIZE A4 PPROJECTION

X, \pm
X ± 0.38
.XX ± 0.25
.XXX ± 0.10
ANG \pm

照片框

ORDER INFORMATION

SDC-W26PA190R-09-LF

SERIES | | | | | LEADFREE
09 WAY
REEL
90° SMT PAD TO POST 19.25mm
POST 26.40mm UPPER CONTACT
PUSH PUSH

DESCRIPTION: SD CARD PUSH PUSH REVERSE H=3.25

煜倫股份有限公司

www.morethanall.com

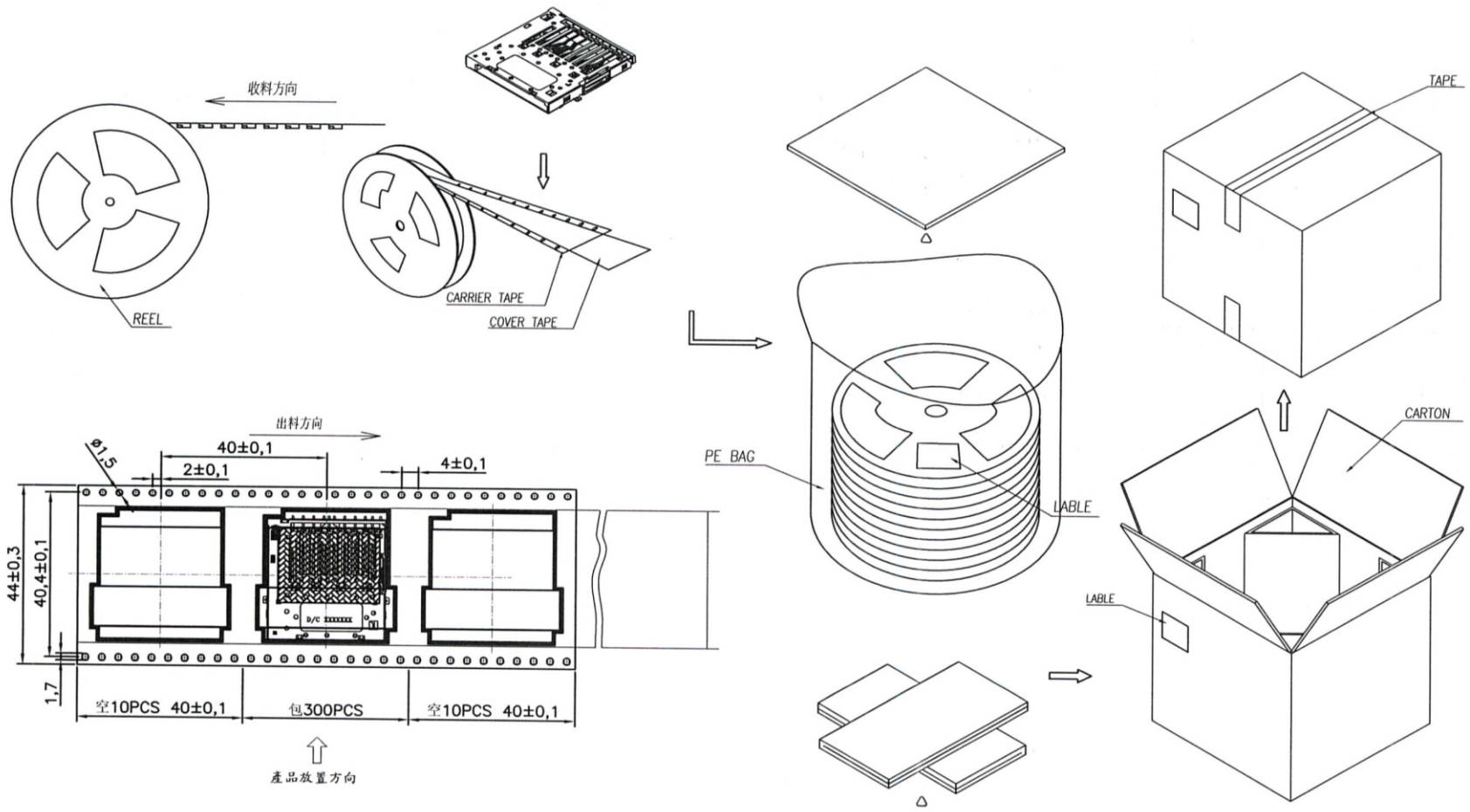

QUANTITY OF PER REEL	300PCS/REEL
QUANTITY OF PER CARTON	6*300=1800PCS/CARTON
WEIGHT OF PER REEL	
WEIGHT OF PER CARTON (NET WEIGHT)	
GROSS WEIGHT	
CARTON SIZE	350*350*325mm

RoHS Compliant

TOLERANCES ARE

照片框

ORDER INFORMATION

SDC-W26PA190R-09-LF
 SERIES | | | | | LEADFREE
 | | | | | 09 WAY
 REEL
 90°SMT PAD TO POST 19.25mm
 POST 26.40mm UPPER CONTACT
 PUSH PUSH

DESCRIPTION:

MORETHANALL
 PCB CONNECTORS
 Cable ASSEMBLIES
 煜倫股份有限公司
 www.morethanall.com

DRAWING BY CY		X, ± X ± 0.38 .XX ± 0.25 .XXX ± 0.10 ANG ±
CHECKED BY GENIUS		
UNIT / mm	SCALE 1 : 1	
DATE		
SIZE A4	PPOJECTION	