

DESCRIPTION

RECOMMENDED PANEL THICKNESS 1.60±0.1

MECHANICAL :

	MATERIAL	Q'TY
1. SC HOUSING	PBT(UL 94-V0)	2
2. HOLDER	PBT(UL 94-V0)	2
3. SLEEVE	PHOSPHOR BRONZE	1
4. CLIP	STAINLESS	1
5. DUST COVER	PP	2

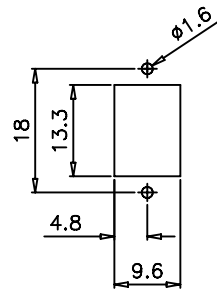
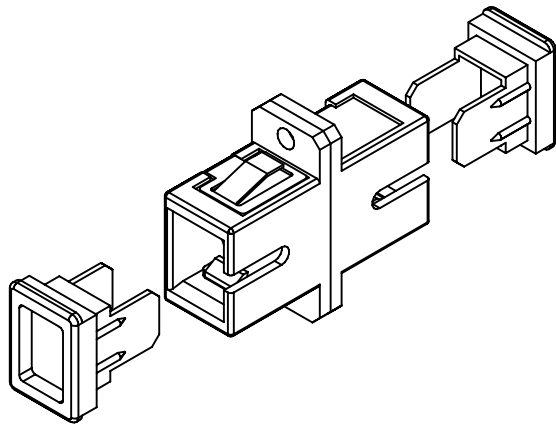

SUGGESTED PANEL CUTOUT



PART NO. **SCX2-FSM-01**

DWG NO. **SCX2-FSM-01**

FILE NO.

UNIT / mm

SCALE 1:1

CHECKED BY CY

DRAWING BY

PROJECTION

TOLERANCES ARE

.X ±
.XX ±
.XXX ±
AWG

DESCRIPTION: C Adaptor-Simplex Type(MM`

AREA	REVISIONS	HK	DATE
------	-----------	----	------

焯倫有限公司