

# TECHNICAL CHARACTERISTICS

## 1. General Characteristics

Dimension: 29.65L x 17.20W x 2.00H mm  
 Weight: Approx. 0.75 g  
 Contact principle: Friction technology  
 Operating position: Shaft up / Down / Horizontal  
 Mounting System: SMT Type (post optional)  
 Durability: 10,000 cycles min.

## 2. Mechanical Characteristics

Insulation material: Thermoplastic, UL 94V-0  
 RoHS Directive 2011/65/EU Compliant

## 3. Electrical Characteristics

Number of contacts: 6, 8 pins (optional)  
 Contact resistance: 50  $\Omega$  typical, 100  $\Omega$  max.  
 Insulation resistance: >1000 M $\Omega$  / 500 VDC  
 Switch type: Blade  
 Operation: Normally Open

## 4. Solderability

Wave: Not applicable  
 IR reflow: 260°C, 10 sec. Max.  
 Manual soldering: 360°C, 3 sec. Max.

## 5. Environmental Characteristics

Operating temperature: - 40°C ~ + 85°C  
 Operating humidity: 10 % ~ 95 % RH  
 Storage temperature: - 40°C ~ + 85°C  
 Storage humidity: 10 % ~ 95 % RH

### Note:

- Coplanarity of solder pins 0.10mm max.
- Recommended thickness of solder paste > 0.15mm.

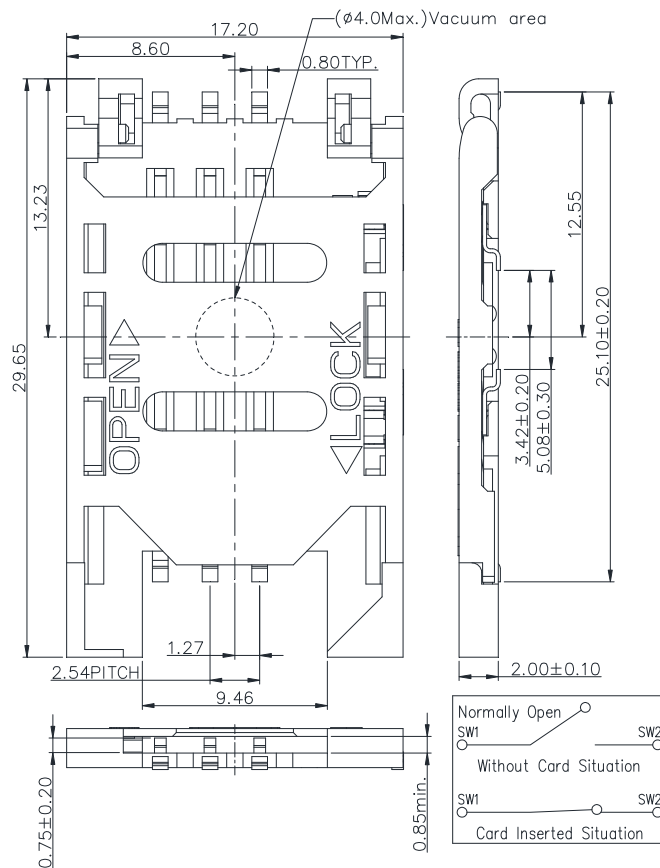

Unit: mm; Tolerances:  $\pm 0.15$  mm  
**Mechanical outline dimension**

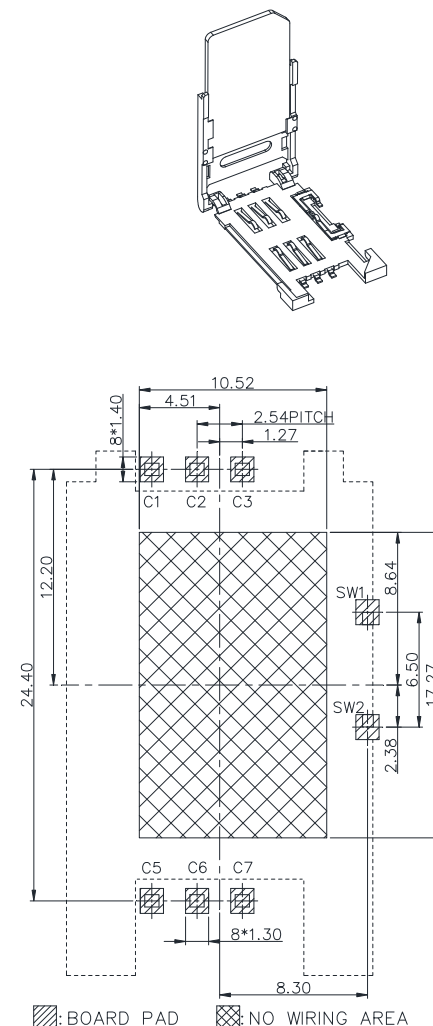

Unit: mm; Tolerances:  $\pm 0.05$  mm  
**Reference dimension for PCB layout**

**RoHS Compliant**

TOLERANCES ARE

**MORETHANALL**  
 PCB CONNECTORS  
 Cable ASSEMBLIES

DRAWING BY CY

CHECKED BY GENIUS

UNIT / mm

SCALE 1 : 1

DATE

SIZE A4

PJECTION

X,  $\pm$   
 X,  $\pm$   
 .XX,  $\pm$   
 .XXX,  $\pm$   
 ANG,  $\pm$

照片框

**ORDER INFORMATION**

**SCV-W2420XBR-06-LF**

SERIES

LEADFREE

06WAY

REEL

OPEN SWITCH

NON POST

BODY HIGH 2.0mm

90°SMT  
 PAD TO PAD 24.40mm

DESCRIPTION:

**煜倫股份有限公司**

[www.morethanall.com](http://www.morethanall.com)

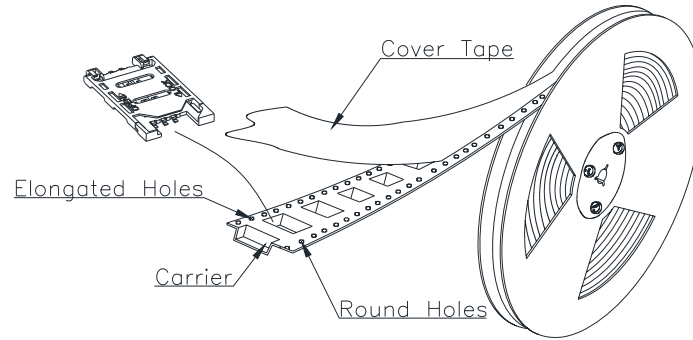

N.W.: 0.45 KGS  
 G.W.: 1.00 KGS  
 QTY: 600 PCs per reel  
 Meas.: dia. 33 CM, W 4.4 CM

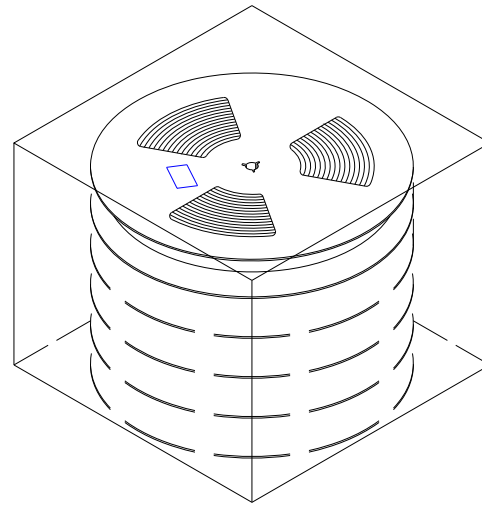

N.W.: 2.7 KGS  
 G.W.: 7.6 KGS  
 QTY: 3,600 PCs per carton  
 (6 reels set in order)  
 Meas.: 36.5L x 36.5W x 36.0H CM

**MORETHANALL**  
 PCB CONNECTORS  
 Cable ASSEMBLIES

煜倫股份有限公司

www.morethanall.com

RoHS Compliant

DRAWING BY CY  
 CHECKED BY GENIUS  
 UNIT / mm SCALE 1:1  
 DATE  
 SIZE A4

TOLERANCES ARE

X. ±  
 .X ±  
 .XX ±  
 .XXX ±  
 ANG ±

PPOJECTION

照片框

ORDER INFORMATION

SCV-W2420XBR-06-LF  
 SERIES REEL OPEN SWITCH NON POST BODY HIGH 2.0mm  
 LEADFREE 06WAY  
 90°SMT  
 PAD TO PAD 24.40mm

DESCRIPTION: