

## TECHNICAL CHARACTERISTICS

### 1. General Characteristics

Dimension: 13.90L x 16.30W x 2.40H mm  
 Weight: Approx. 0.35 g  
 Contact principle: Friction technology  
 Operating position: Shaft up / Down / Horizontal  
 Mounting System: SMT Type (without post)  
 Durability: 5,000 cycles min.

### 2. Mechanical Characteristics

Insulation material: Thermoplastic, UL 94V-0  
 RoHS Directive 2002/95/EC Compliant

### 3. Electrical Characteristics

Number of contacts: 6, 8 pins (optional)  
 Contact resistance: 50 mΩ typical, 100 mΩ max.  
 Insulation resistance: >1000 MΩ / 500 VDC

### 4. Solderability

Wave: Not applicable  
 IR reflow: 260°C, 10 sec. Max.  
 Manual soldering: 360°C, 3 sec. Max.

### 5. Environmental Characteristics

Operating temperature: - 40°C ~ + 85°C  
 Operating humidity: 10 % ~ 95 % RH  
 Storage temperature: - 40°C ~ + 85°C  
 Storage humidity: 10 % ~ 95 % RH

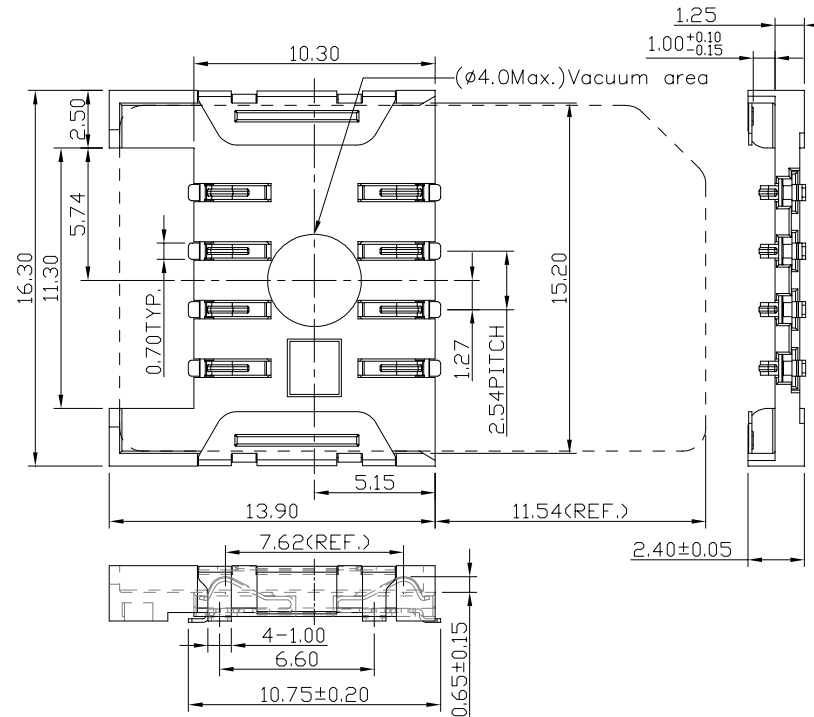

Unit: mm; Tolerances: ±0.15 mm  
**Mechanical outline dimension**

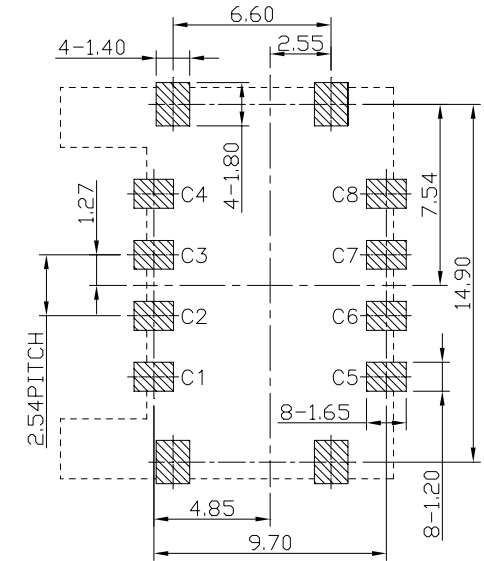

Unit: mm; Tolerances: ±0.05 mm  
**Reference dimension for PCB layout**

**RoHS Compliant**

TOLERANCES ARE

**MORETHANALL**  
 PCB CONNECTORS  
 Cable ASSEMBLIES

DRAWING BY CY

X. ±

CHECKED BY GENIUS

.X ±

UNIT / mm

SCALE 1 : 1

.XX ±

DATE

.XXX ±

ANG ±

SIZE A4

P PROJECTION

照片框

**ORDER INFORMATION**

SCU-W0924X-08-LF  
 SERIES | LEADFREE  
 | 08 WAY  
 | NON POST  
 | BODY HIGH 2.4mm  
 | PAD TO PAD 9.7mm  
 90°SMT

DESCRIPTION:

煜倫股份有限公司

www.morethanall.com