

### Specification

#### MATERIAL:

Insulator: High Temperature Thermoplastic,  
Color Black ,UL 94V-0.

Contact: Beryllium Copper

Shell: Stainless Steel

#### PLATING:

Contact: Plated 50u" Ni Overall

Plated Au Selective Contact Area

Plated 100u" Sn&Au Over Nickel On Solder Area

Shell: Plated 50u" Ni Overall

Plated Au Selective Solder Area

#### Electrical:

Current Rating :0.5mA max.

Contact Resistance:100mΩ max.

Insulation Resistance:1000MΩ min./500VDC

Dielectric Withstanding Voltage:500VAC/1 minute

Operating Temperature:-25°C TO+85°C

Mating Cycles:7,000 Insertions

#### Usable Memory Card:

micro SD&SIM Card

SCTF-W17TP-0608-LF

LEADFREE

RoHS Compliant

**MORETHANALL**  
CONNECTORS  
ASSEMBLIES

PART NO. SCTF-W17TP-0608

DWG NO. SCTF-W17TP-0608

CHECKED BY CY

TOLERANCES ARE

DESCRIPTION: micro SD push-push+SIM

FILE NO.

DRAWING BY

.X ± 0.2

.XX ±

.XXX ±

AWG

AREA

REVISIONS

HK

DATE

煜倫股份有限公司

UNIT / mm

SCALE 1:1

PROJECTION

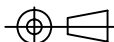

Recommend PCB Layout Drawing:  
 (Unit:mm .X ± 0.25 .XX ±0.15 .XXX ± 0.05)

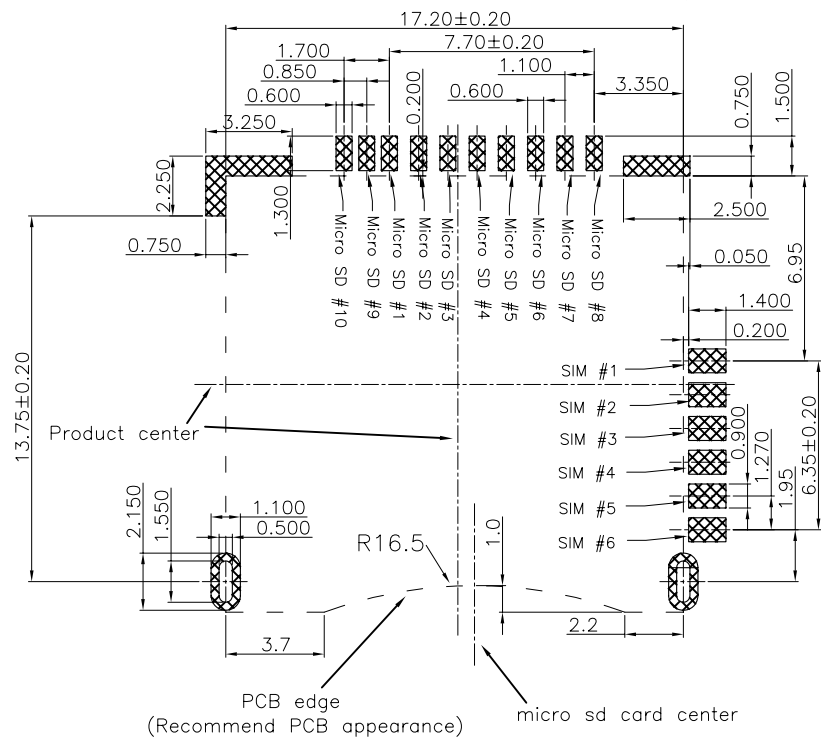

RECOMMEND PCB printing net of steel:

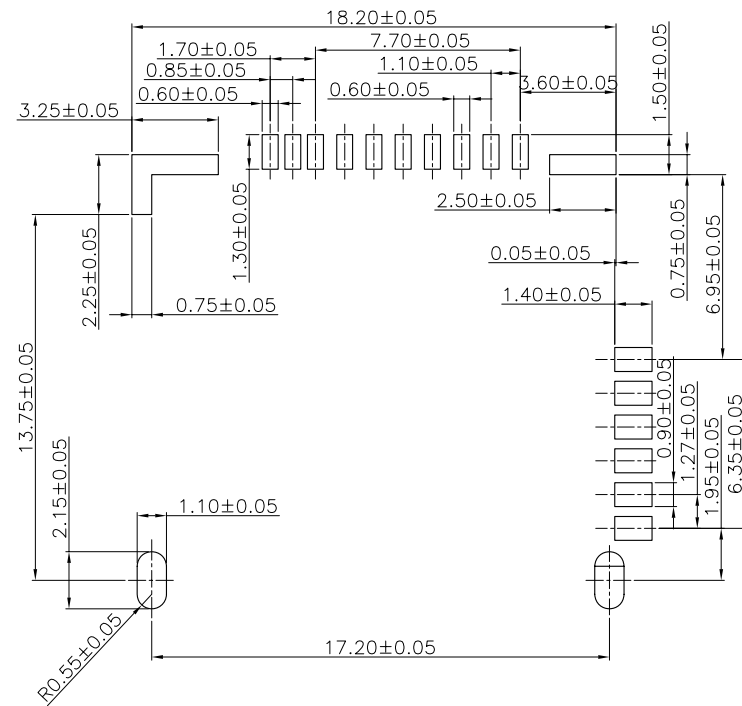

PIN ASSIGNMENT:

Micro SD #1	Micro SD DAT2	SIM #1	SIM I/O
Micro SD #2	Micro SD CD/DAT3	SIM #2	SIM CLK
Micro SD #3	Micro SD CMD	SIM #3	SIM VPP
Micro SD #4	Micro SD VDD	SIM #4	SIM RST
Micro SD #5	Micro SD CLK	SIM #5	SIM GND
Micro SD #6	Micro SD VSS	SIM #6	SIM VCC
Micro SD #7	Micro SD DAT0		
Micro SD #8	Micro SD DAT1		
Micro SD #9	CD		
Micro SD #10	GROUND		

SCTF-W17TP-0608-LF

LEADFREE

RoHS Compliant

**MORETHANALL**  
CONNECTORS  
ASSEMBLIES

PART NO. SCTF-W17TP-0608

DWG NO. SCTF-W17TP-0608

CHECKED BY CY

FILE NO.

DRAWING BY

TOLERANCES ARE

.X ± 0.2  
.XX ±  
.XXX ±  
AWG

DESCRIPTION: micro SD push-push+SIM

煜倫股份有限公司

UNIT / mm

SCALE 1:1

PROJECTION

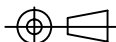

AREA

REVISIONS

HK

DATE

MICRO SD OR SIM CARD INSERT DRAWIGN:

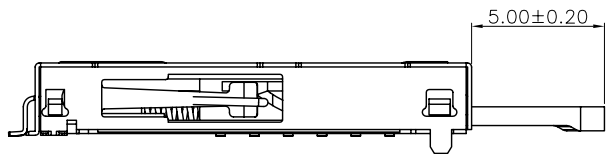

Micro Secure Digital -Un Lock

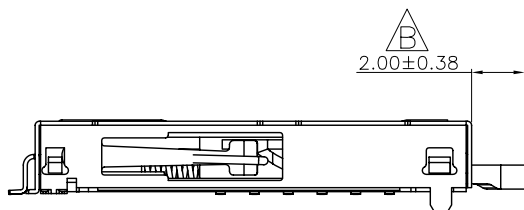

Micro Secure Digital -Lock

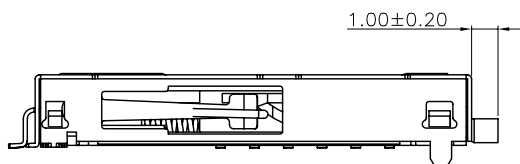

Micro Secure Digital -Push

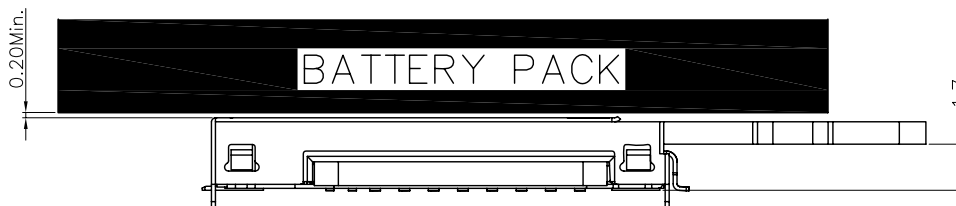
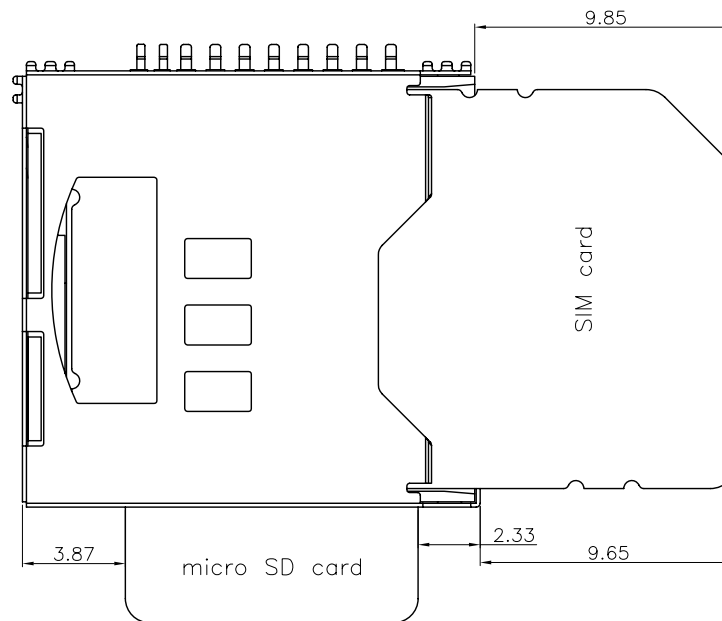

**MORETHANALL**  
CONNECTORS  
ASSEMBLIES

PART NO. SCTF-W17TP-0608

DWG NO. SCTF-W17TP-0608

CHECKED BY CY

TOLERANCES ARE

DESCRIP TION: micro SD push-push+SIM

FILE NO.

DRAWING BY

.X ± 0.2  
.XX ±  
.XXX ±  
AWG

煜倫股份有限公司

UNIT / mm

SCALE 1:1

PROJECTION

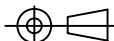

AREA

REVISIONS

HK

DATE

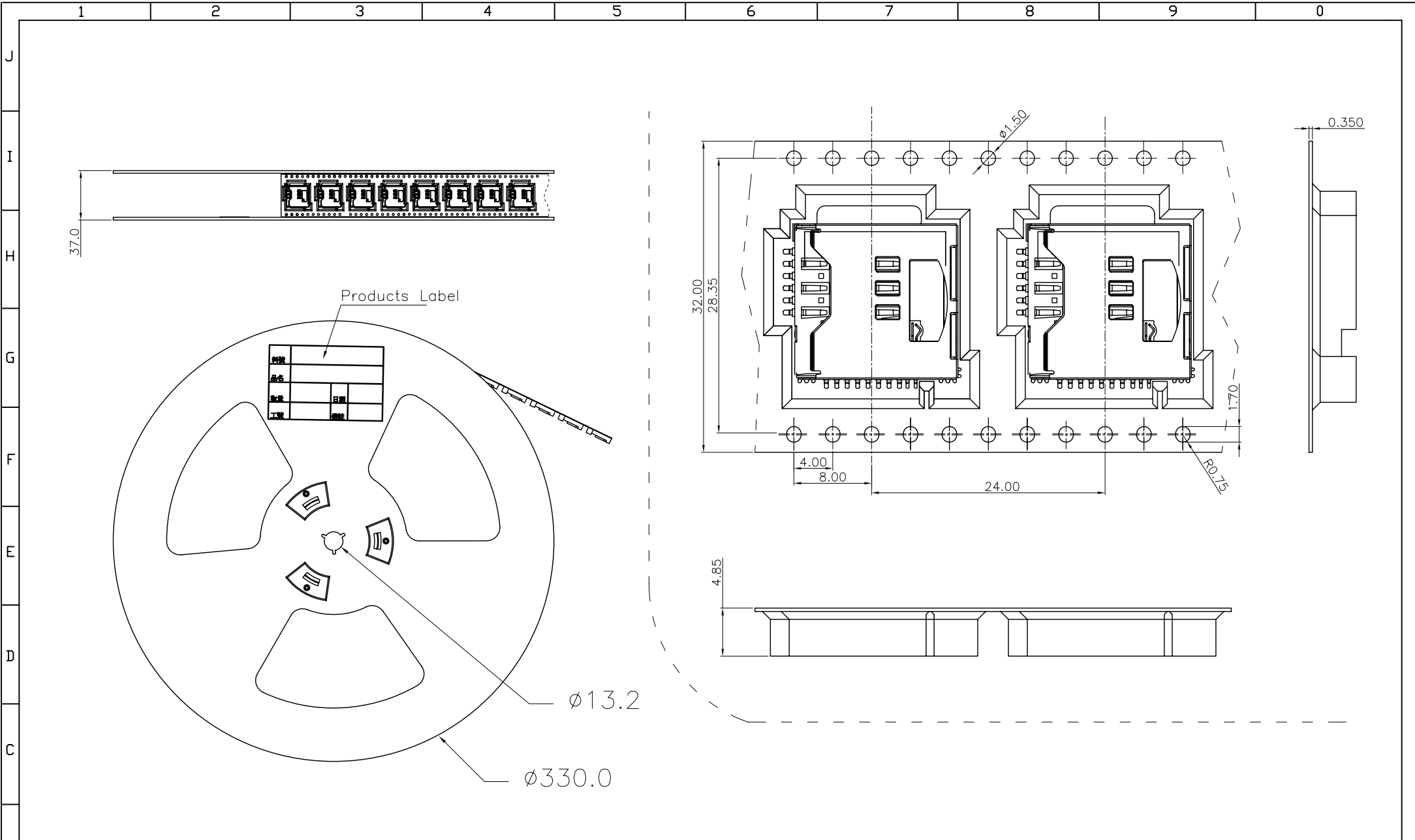

**M** MORETHANALL  
CONNECTORS  
ASSEMBLIES

PART NO. SCTF-W17TP-0608

DWG NO. SCTF-W17TP-0608

CHECKED BY CY

TOLERANCES ARE

DESCRIPTION: micro SD push-push+SIM

FILE NO.

DRAWING BY

.X ± 0.2  
.XX ±  
.XXX ±  
AWG

煜倫股份有限公司

UNIT / mm

SCALE 1:1

PROJECTION

AREA	REVISIONS	HK	DATE
------	-----------	----	------