

NOTE:

- 1.MATERIAL :  
 BASE:HIGH THERMOPLASTIC UL94V-0, COLOR : BLACK  
 TERMINAL: COPPER ALLOY, T= 0.30 mm
- 2.PLATING:  
 CONTACT:GOLD PLATED ON THE CONTACT.  
 TIN PLATED ON THE SOLDER TAIL.  
 NICKEL UNDERPLATED OVER ALL.
- 3.ELECTRONICAL SPECIFICATION:  
 CURRENT RATING: 1.5 AMPERE PER CONTACT  
 CONTACT RESISTANCE: 30 MILLIOHMS MAX.  
 INSULATION RESISTANCE: 1000 MEGOHMS MIN.  
 DIELECTRIC WITHSTANDING VOLTAGE: 500 VAC.  
 OPERATING TEMPERATURE: -40°C~+85°C

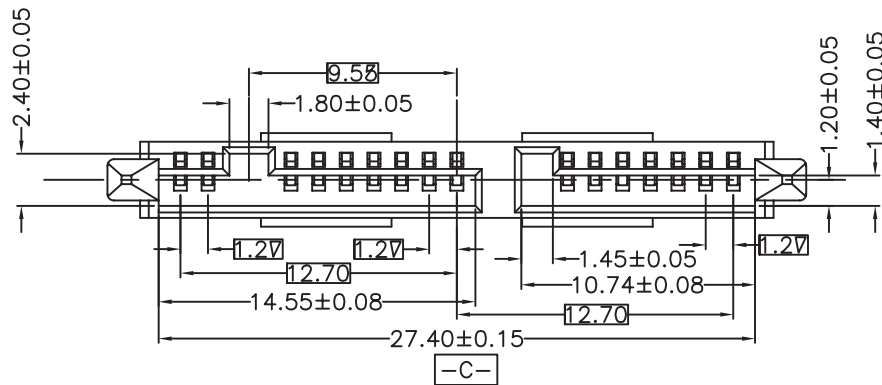

**RoHS Compliant**

TOLERANCES ARE

**MORETHANALL**  
 PCB CONNECTORS  
 Cable ASSEMBLIES

DRAWING BY CY

CHECKED BY GENIUS

UNIT/ mm SCALE 1:1

DATE

SIZE A4

X. ±  
 .X ±  
 .XX ±  
 .XXX ±  
 ANG ±

PJECTION

照片框

**ORDER INFORMATION**

SATA-SS-2+7+7-LF

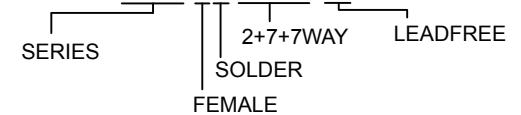

煜倫股份有限公司

www.morethanall.com

DESCRIPTION: SATA 16P SOCKET SOLDER TYPE