

PART NO. 編號	SPEC. 規格	PITCH 間距	MM ² 線徑	AWG WIRE SIZE	MATERIAL 材質	FINISH 表面處理	PACKING Q'TY 包裝數量	REMARK 備註
	BSS	14.35	0.8~1.3	18~16	黃銅 BRASS	預鍍錫 Pre-Tin	4000/R	

NOTES:

- 1.表面處理：預鍍錫 60u" 以上
- 2.插入力：2.5 KGf 以下
拔出力：拔出力：3 KGf 以上

- 1.Finish : Pre-Tin 60u" min.
- 2.INSERTED/TENSILE FORCES:
INSERTED FORCE: 2.5 KGf MAX.
TENSILE FORCE: 3 KGf MIN .

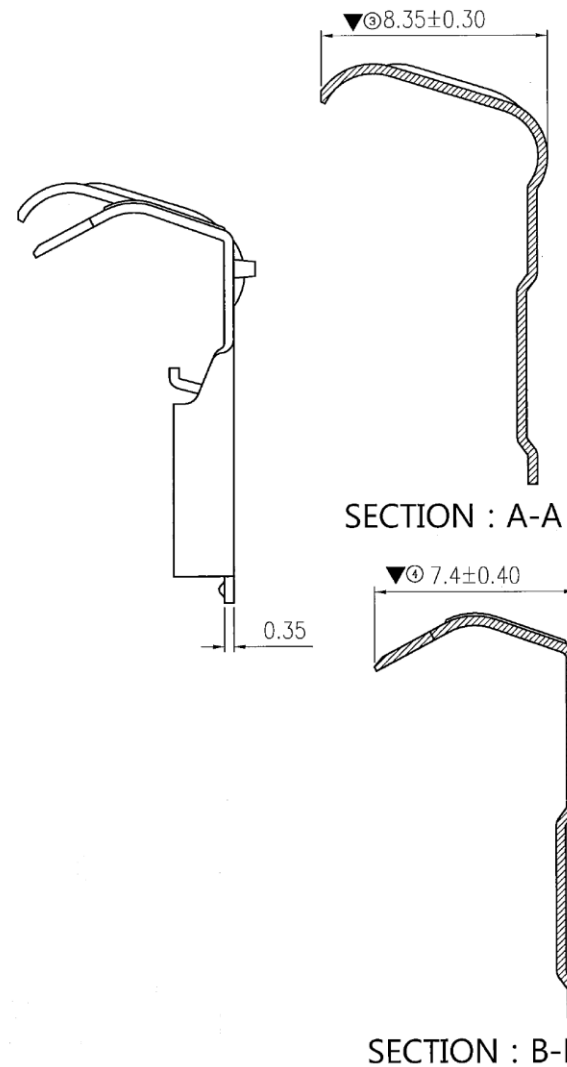
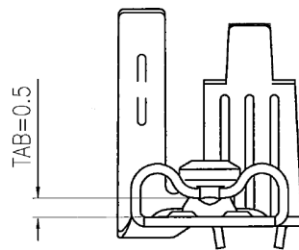
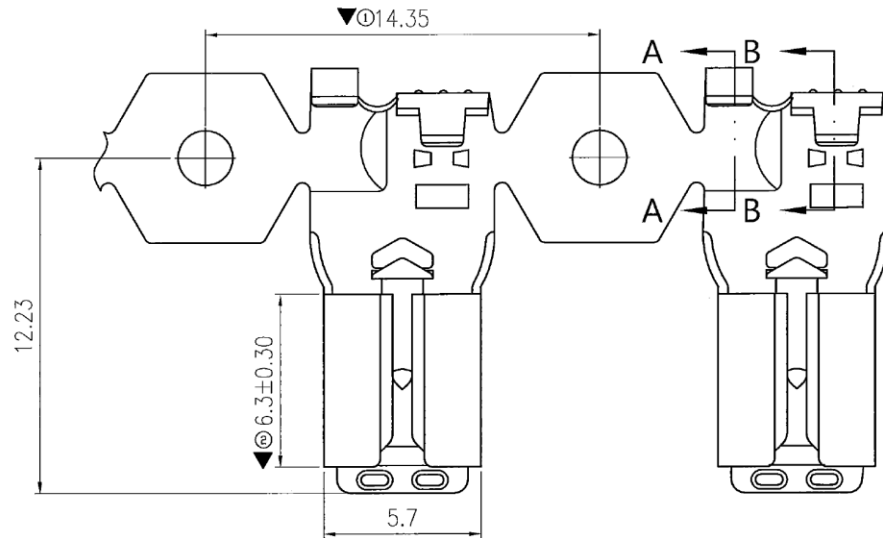

RoHS Compliant

TOLERANCES ARE

MORETHANALL
PCB CONNECTORS
Cable ASSEMBLIES

DRAWING BY CY

X.±

CHECKED BY GENIUS

.X±

UNIT / mm

SCALE 1:1

.XX±

DATE

.XXX±

ANG±

SIZE A4

PJECTION

照片框

ORDER INFORMATION

Q187-GT5-16-LF

SERIES LEADFREE
16~18AWG
0.5t
TERMINAL
FLAG

煜倫股份有限公司

www.morethanall.com

DESCRIPTION: