

T:1.6 Dimensions of PC board holes
Tolerance : ±0.1(Printed-top view)

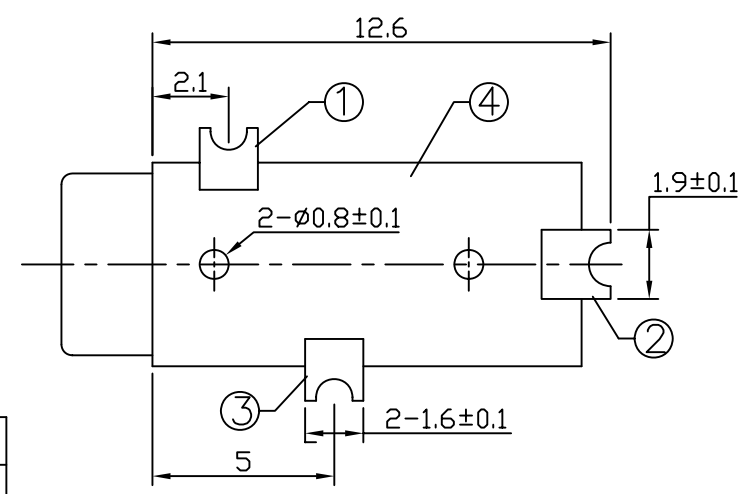

PJ-W17R-xx-LF
LEADFREE
RoHS Compliant

SCHEMATIC	
PJ-W17R-03	PJ-W17R-02

UNLESS OTHERWISE SPECIFIED, TOLERANCE ON DECIMAL: ±0.2

4	HOUSING	1	PA9T	UL-94V0(BLACK)
3	CONTACT FOOT	1	C5191	MB:Ni Ag PLATED
2	CONTACT FOOT	1	C5191	MB:Ni Ag PLATED
1	CONTACT FOOT	1	C5191	MB:Ni Ag PLATED
LTR	PART NAME	QTY	MATERIAL	REMARK

	PART NO. PJ-W17R-xx		CHECKED BY CY	TOLERANCES ARE .X ± 0.2 .XX ± .XXX ± ANG	DESCRIP TION:			
	DWG NO. PJ-W17R-xx							
	FILE NO.		PROJECTION	AREA	REVISIONS	HK	DATE	
	UNIT / mm	SCALE 1:1						

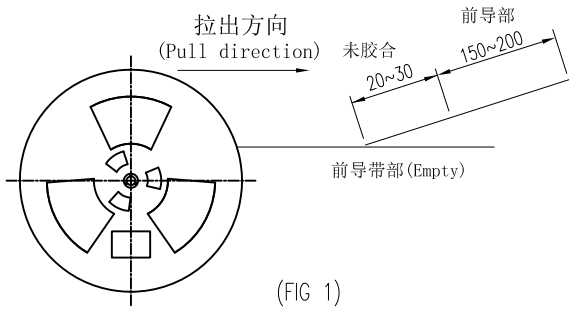

(FIG 1)

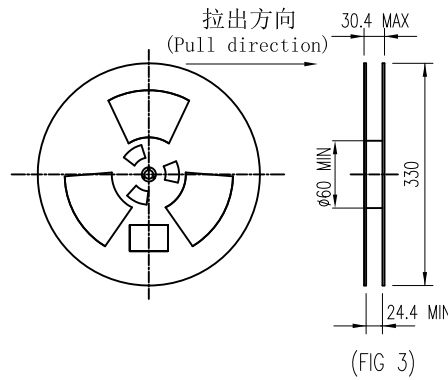

(FIG 3)

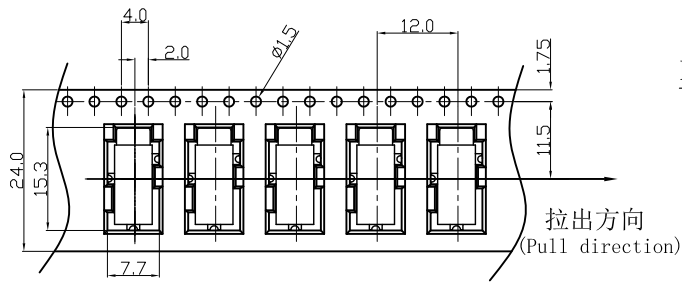

(FIG 2)

Reel外觀尺寸?D



1 REEL
= 900 PCS

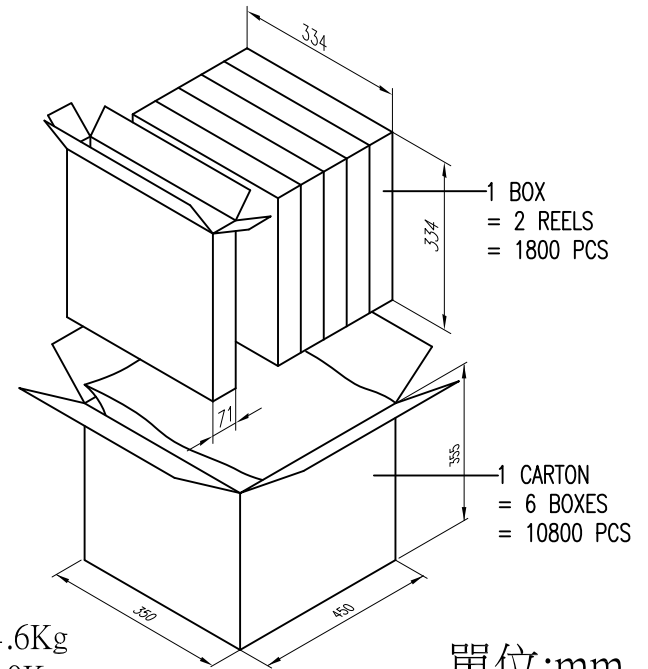

淨重: 4.6Kg
毛重: 6.0Kg

單位:mm

REMARK:

- The connector can not be loaded on the position of length 240~360mm in the reel tape and lead tape. The cover tape with 20~30mm length shall not be adhesive on the lead tape and the cover tape is lead portion shall have 150~200mm length (Refer FIG 1).
- Tape shall turn on right direction.
- The direction of connector is fixed regarding the position of terminal, please refer outline drawing (Refer FIG 2).
- After winding, using the adhesive tape (30~50mm) to stick the leader of cover tape on the side of reel.
- One reel can be loaded 900 pcs connector.
- The label shall be pasted on the front side of reel (Refer FIG 3).
- Condition of 300mm per minute, the extraction strength of cover tape shall reach 20~150 gf.
- If the quantity is less than 6 reel in one carton, the packing shall be able to resist to shock.

MORETHANALL
CONNECTORS
ASSEMBLIES

PART NO. PJ-W17R-xx

DWG NO. PJ-W17R-xx

FILE NO.

UNIT / mm

SCALE 1:1

CHECKED BY CY

DRAWING BY

PROJECTION

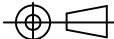

TOLERANCES ARE

.X ± 0.2
.XX ±
.XXX ±
ANG

DESCRIPTION:

AREA

REVISIONS

HK

DATE

焯倫股份有限公司