

RoHS Compliant

TOLERANCES ARE

MORETHANALL
PCB CONNECTORS
Cable ASSEMBLIES

DRAWING BY CY

X.±

CHECKED BY GENIUS

.X±

UNIT / mm

SCALE 1 : 1

.XX±

DATE

.XXX±

ANG±

SIZE A4

PJECTION



ORDER INFORMATION

PCC-PWL40V3RS-68-LF
SERIES | | | | | LEADFREE
MALE | | | | | 68WAY
DIP 90° | | | | | 3.0V RIGHT STRAIGHT
STANDOFF 4.0mm
LONG RAIL

煜倫股份有限公司

www.morethanall.com

DESCRIPTION: PCMCIA ASSEMBLY

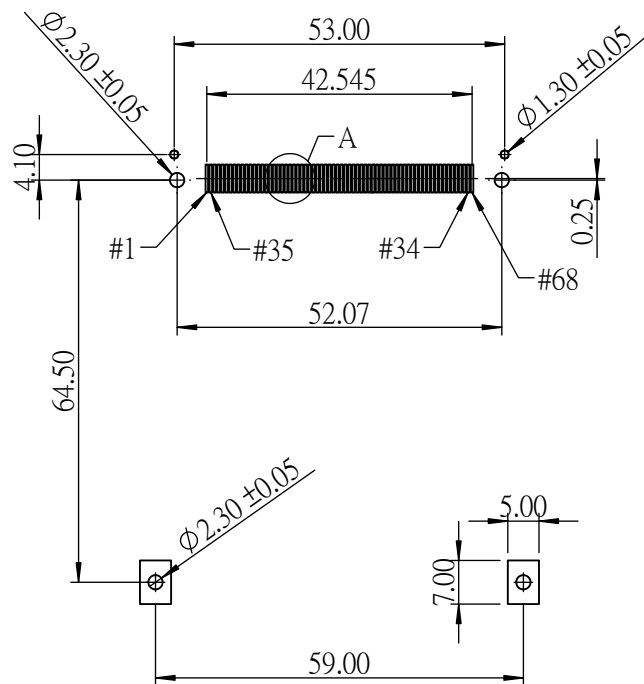

PCB LAYOUT : COMPONENT SIDE

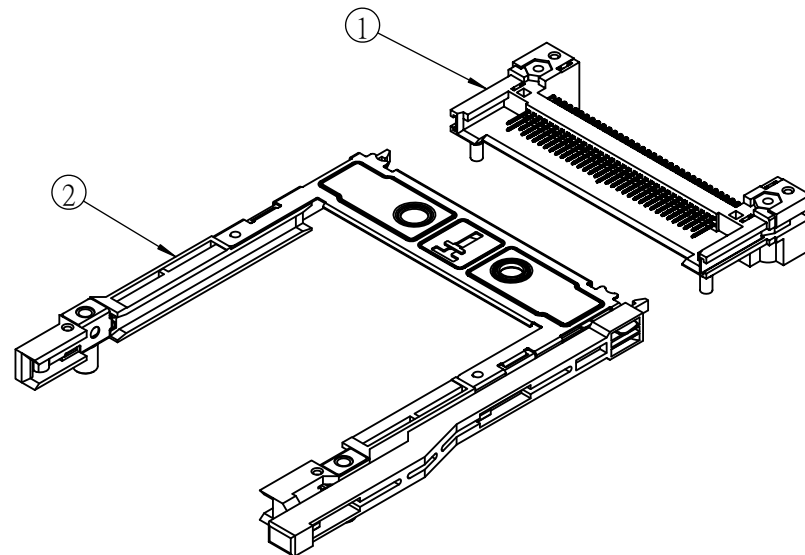
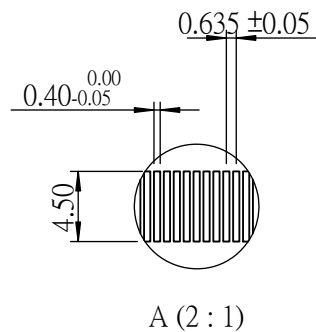

ITEM	NAME
1	HEADER
2	EJECTOR

RoHS Compliant

TOLERANCES ARE

MORETHANALL
PCB CONNECTORS
Cable ASSEMBLIES

DRAWING BY CY

X. ±

CHECKED BY GENIUS

.X ±

UNIT / mm SCALE 1 : 1

.XX ±

DATE

.XXX ±

ANG ± 1°

SIZE A4

P PROJECTION

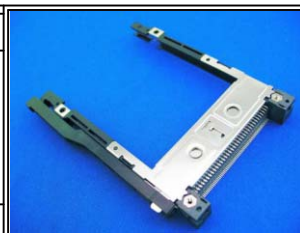

ORDER INFORMATION

PCC-PWL40V3RS-68-LF
SERIES | LEADFREE
MALE | 68WAY
DIP 90° | 3.0V | RIGHT STRAIGHT
STANDOFF 4.0mm
LONG RAIL

煜倫股份有限公司

www.morethanall.com

DESCRIPTION: PCMCIA ASSEMBLY

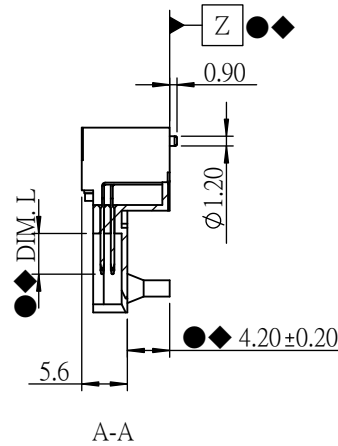
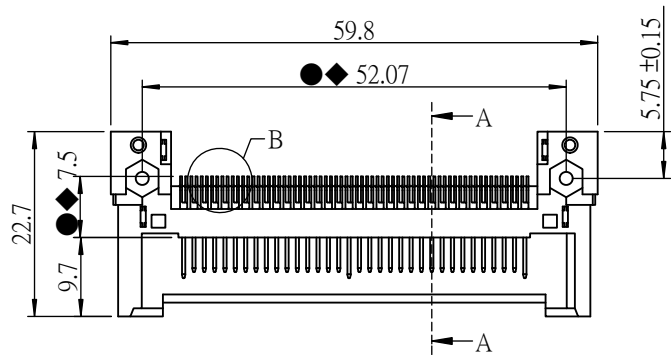

NOTE:

- SOLDERTAIL TO BE WITHIN 0.05 UPWARD AND 0.2 DOWNWARD FROM Z-DATUM PLACE, AND COPLANALITY OF SOLDERTAILS TO BE WITHIN 0.12. MEASUREMENT POINT IS SOLDERTAILS TIP.
- INSPECTION SYMBOL:
 ● : MANUFACTURER INSPECTION
 ◆ : Q.C INSPECTION
- PLEASE REFER TO TABLE 1 FOR TERMINAL LENGTH. TABLE 1

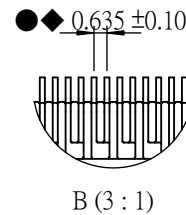
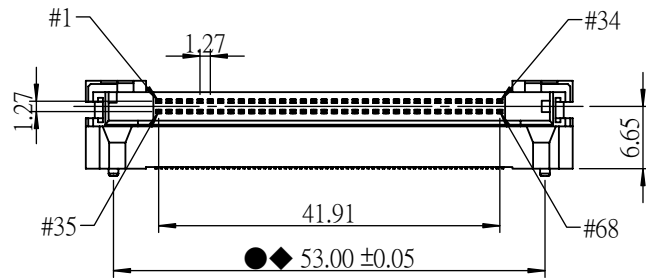

PIN TYPE	DIM. L ±0.20	PIN NUMBER
DETECT	3.50 mm	36 , 67
GENERAL	4.25 mm	THE REST
POWER	5.00 mm	1, 17, 34, 35, 51, 68

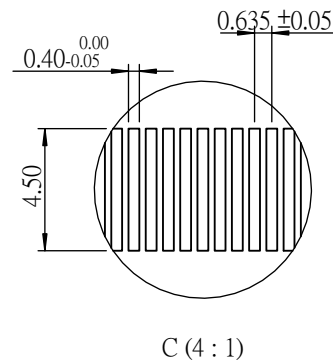
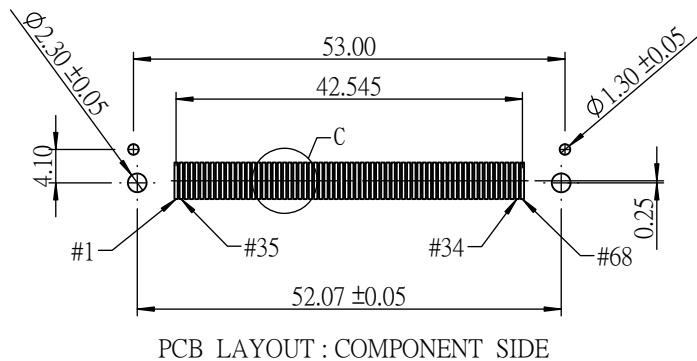

RoHS Compliant

TOLERANCES ARE

MORETHANALL
PCB CONNECTORS
Cable ASSEMBLIES

DRAWING BY CY

X. ±

CHECKED BY GENIUS

.X ±

UNIT / mm

SCALE 1 : 1

.XXX ±

DATE

ANG ±

SIZE A4

PJECTION



ORDER INFORMATION

PCC-PWL40V3RS-68-LF
 SERIES | | | | LEADFREE
 MALE | | | | 68WAY
 DIP 90° | | | | 3.0V RIGHT STRAIGHT
 | | | | LONG RAIL STANDOFF 4.0mm

煜倫股份有限公司

www.morethanall.com

DESCRIPTION: