

RoHS Compliant

TOLERANCES ARE

MORETHANALL
PCB CONNECTORS
Cable ASSEMBLIES

DRAWING BY CY

X.±

CHECKED BY GENIUS

.X±

UNIT / mm

SCALE 1 : 1

.XX±

DATE

.XXX±

ANG±

照片框

ORDER INFORMATION

PCC-PWL22V3-68-LF
SERIES | | | LEADFREE
MALE | | | 68WAY
3.3V
STAND OFF 2.2mm
LONG RAIL
90°SMT

煜倫股份有限公司

www.morethanall.com

SIZE A4

P PROJECTION

DESCRIPTION: PCMCIA ASSEMBLY

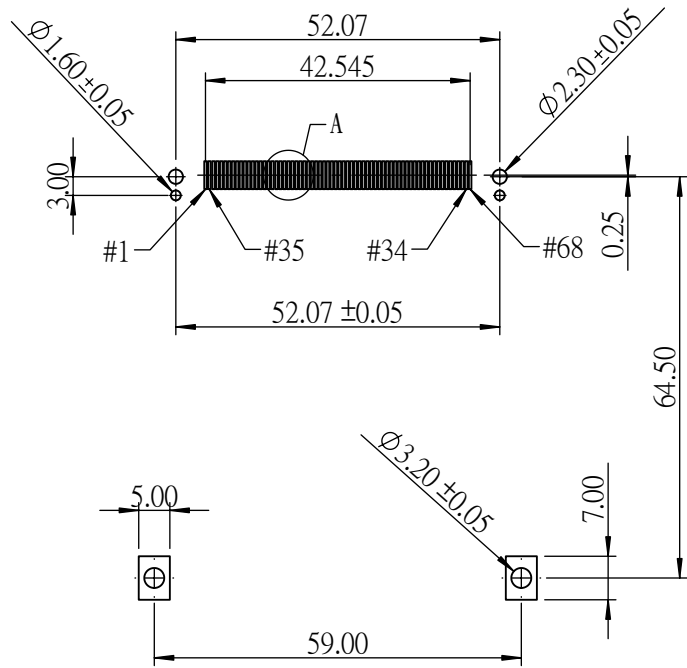

PCB LAYOUT : COMPONENT SIDE

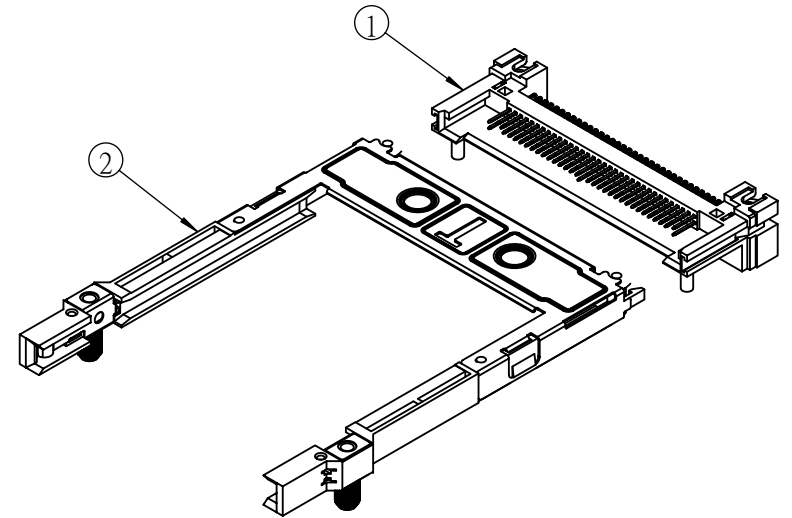
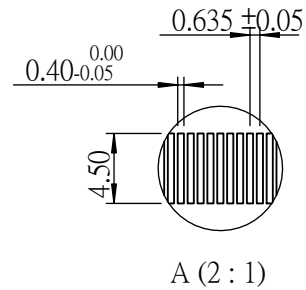

ITEM	PART NO.	NAME
1		HEADER
2		GUIDING RAIL

RoHS Compliant

TOLERANCES ARE

MORETHANALL
PCB CONNECTORS
Cable ASSEMBLIES

DRAWING BY CY
CHECKED BY GENIUS
UNIT / mm SCALE 1 : 1
DATE

X. ±
.X ±
.XX ±
.XXX ±
ANG ±

照片框

ORDER INFORMATION

PCC-PWL22V3-68-LF
SERIES | | | | LEADFREE
MALE | | | | 68WAY
3.3V
STAND OFF 2.2mm
LONG RAIL
90°SMT

煜倫股份有限公司

www.morethanall.com

SIZE A4 PROJECTION

DESCRIPTION: PCMCIA ASSEMBLY

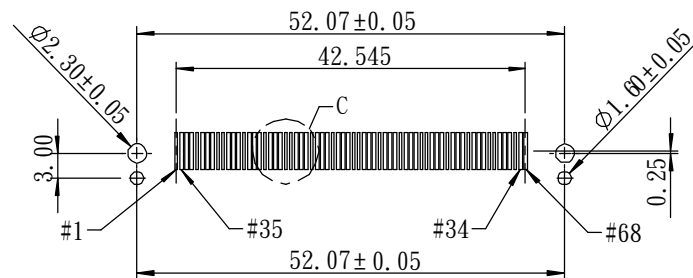
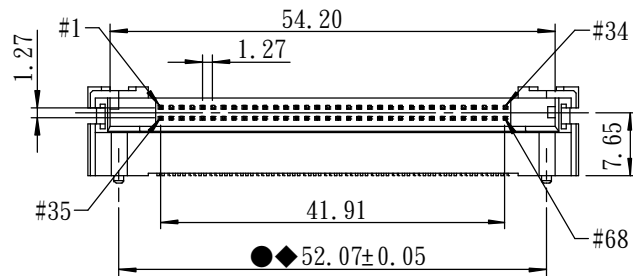
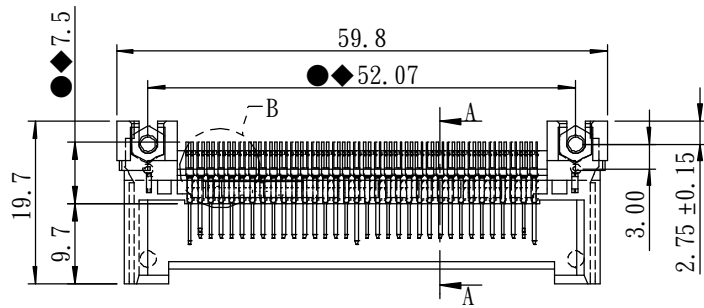

PCB LAYOUT : COMPONENT SIDE

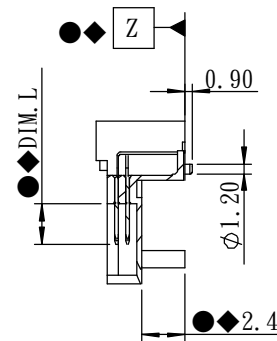

A-A

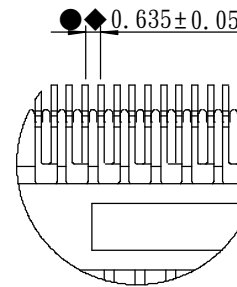

B (3 : 1)

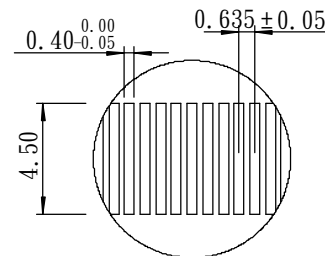

C (3 : 1)

NOTE:

- SOLDERTAIL TO BE WITHIN 0.05 UPWARD AND 0.2 DOWNWARD FROM Z-DATUM PLACE, AND COPLANALITY OF SOLDERTAILS TO BE WITHIN 0.10. MEASUREMENT POINT IS SOLDERTAILS TIP.
- INSPECTION SYMBOL:
 ● : MANUFACTURER INSPECTION
 ◆ : Q.C INSPECTION
- PLEASE REFER TO TABLE 1 FOR TERMINAL LENGTH.
TABLE 1

PIN TYPE	DIM. L ±0.20	PIN NUMBER
DETECT	3.50 mm	36 , 67
GENERAL	4.25 mm	THE REST
POWER	5.00 mm	1, 17, 34, 35, 51, 68

RoHS Compliant

TOLERANCES ARE

MORETHANALL
PCB CONNECTORS
Cable ASSEMBLIES

煜倫股份有限公司

www.morethanall.com

DRAWING BY CY

CHECKED BY GENIUS

UNIT / mm SCALE 1 : 1

DATE

SIZE A4

X, ±

.X ±

.XX ±

.XXX ±

ANG ±

PJECTION

照片框

ORDER INFORMATION

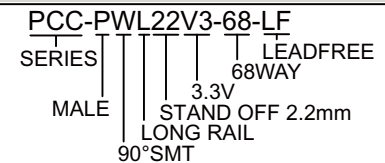

DESCRIPTION: PCMCIA ASSEMBLY