

NOTE:

- SOLDERTAIL TO BE WITHIN 0.05 UPWARD AND 0.2 DOWNWARD FROM Z-DATUM PLACE, AND COPLANALITY OF SOLDERTAILS TO BE WITHIN 0.10. MEASUREMENT POINT IS SOLDERTAILS TIP.
- INSPECTION SYMBOL:
 ● : MANUFACTURER INSPECTION
 ◆ : Q.C INSPECTION
- PLEASE REFER TO TABLE 1 FOR TERMINAL LENGTH. TABLE 1

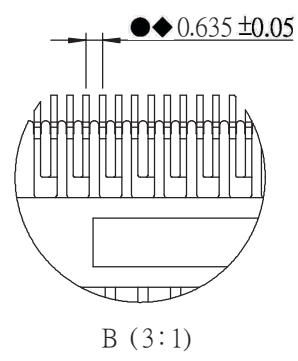

PIN TYPE	DIM. L ±0.20	PIN NUMBER
DETECT	3.50 mm	36 , 67
GENERAL	4.25 mm	THE REST
POWER	5.00 mm	1, 17, 34, 35, 51, 68

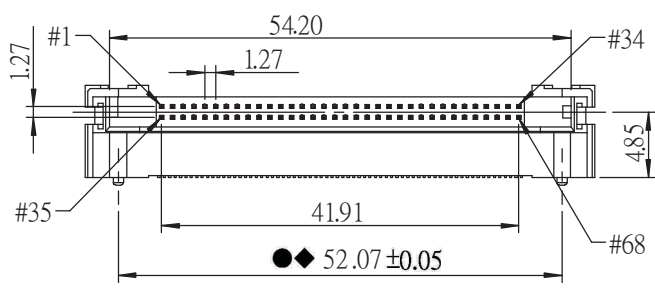
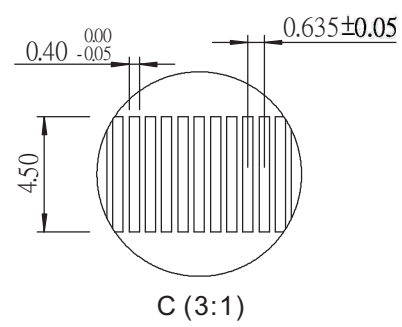
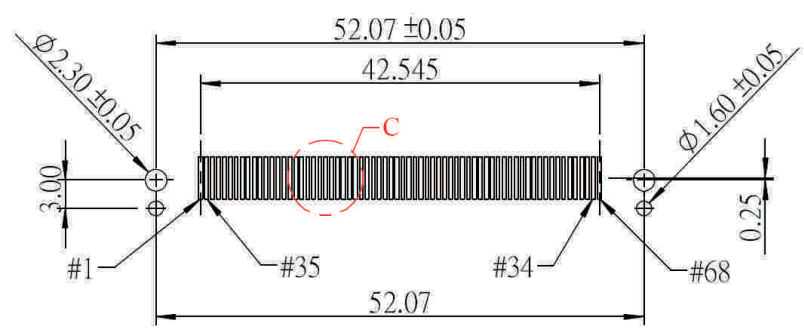

PCC-PW22V5-68-LF
LEADFREE
RoHS Compliant

MORETHANALL
CONNECTORS
ASSEMBLIES

PART NO. PCC-PW22V5-68

DWG NO. PCC-PW22V5-68

FILE NO.

CHECKED BY CY

DRAWING BY

TOLERANCES ARE

.X ± 0.2
.XX ±
.XXX ±
AWG

DESCRIPTION:

煜倫股份有限公司

UNIT / mm

SCALE 1:1

PROJECTION

AREA

REVISIONS

HK

DATE