

PCB LAYOUT : COMPONENT SIDE

NOTE:  
 1. SOLDERTAIL TO BE WITHIN 0.05 UPWARD AND 0.2 DOWNWARD FROM Z-DATUM PLACE, AND COPLANALITY OF SOLDERTAILS TO BE WITHIN 0.12. MEASUREMENT POINT IS SOLDERTAILS TIP.  
 2. INSPECTION SYMBOL:  
 ● : MANUFACTURER INSPECTION  
 ◆ : Q.C INSPECTION  
 3. PLEASE REFER TO TABLE 1 FOR TERMINAL LENGTH.

PIN TYPE	DIM. L ±0.20	PIN NUMBER
DETECT	3.50 mm	36 , 67
GENERAL	4.25 mm	THE REST
POWER	5.00 mm	1, 17, 34, 35, 51, 68

**MORETHANALL**  
 CONNECTORS  
 ASSEMBLIES  
 煜倫股份有限公司

PART NO. **PCC-PW00V3-68**  
 DWG NO. **PCC-PW00V3-68**  
 FILE NO.  
 UNIT / mm    SCALE 1:1

CHECKED BY CY  
 DRAWING BY  
 PROJECTION

TOLERANCES ARE  
 .X ± 0.2  
 .XX ±  
 .XXX ±  
 AWG

DESCRIP TION:	AREA	REVISIONS	HK	DATE

	MATERIAL	P/N	REMARKS
1	TRAY	TRAY 007-007B	42 TRAY X 24 PCS
2	COVER	TRAY 007-007B	2X(1COVER+21TRAY)
3	CARTON	CTN-C100D	CARTON/42 TRAYS/1008CS
4	POLY BAG	P-0001	1 POLY BAG/CARTON
5	LABEL		1 LABEL/CARTON
6	LABEL		1 LABEL/TRAY
7	SCREW	000-FA2I060A	PACKAGE/2X1008PCS/2016PCS
8	TAPE		

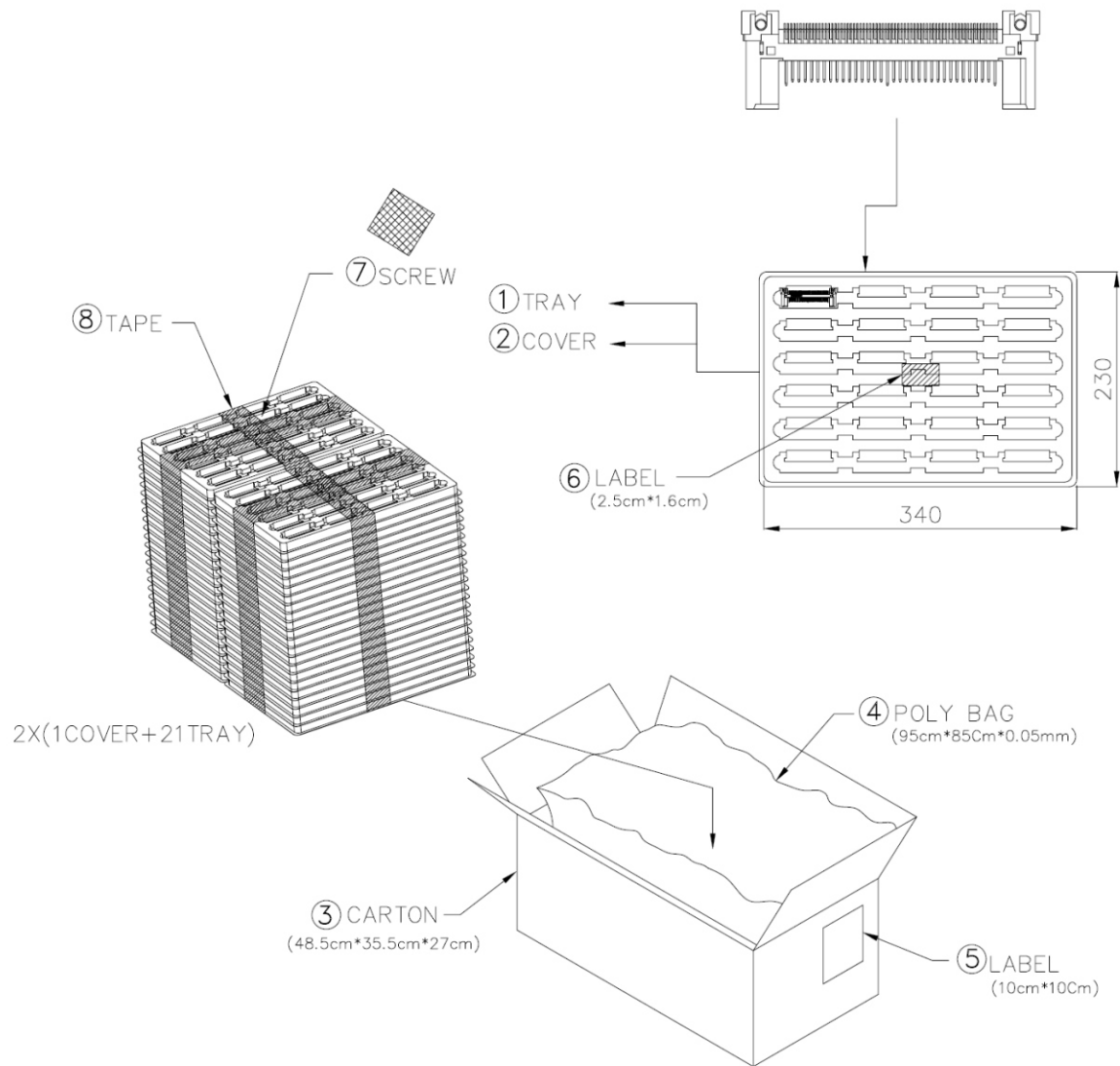

**MORETHANALL**  
CONNECTORS  
ASSEMBLIES

煜倫股份有限公司

PART NO. **PCC-PW00V3-68**

DWG NO. **PCC-PW00V3-68**

FILE NO. **P-007K**

UNIT / mm

SCALE 1:1

CHECKED BY CY

DRAWING BY

PROJECTION

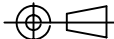

TOLERANCES ARE

.X ± 0.2  
.XX ±  
.XXX ±  
AWG

DESCRIPTION:

AREA

REVISIONS

HK

DATE