

Pin-Header-Strips-Double row for Surface Mount
Technic and High-Temperature Body 1.27mm pitch

Technical data :

Insulator body : High Temperature Thermoplastic,UL 94V-0
 Contact: 0.40mm x 0.40mm copper alloy
 plating: 1 u" Au plated on contact area
 Tin plated on solder area over nickel
 Current Rating : 1 Amp
 Insulator resistance : 500 Megohms min.
 Dielectric withstanding : AC 500 V for 1 minute
 Temperature Rating: -40°C to +105°C.
 Max. processing Temp: 230°C for 30-60 seconds.
 260°C for 10 seconds.

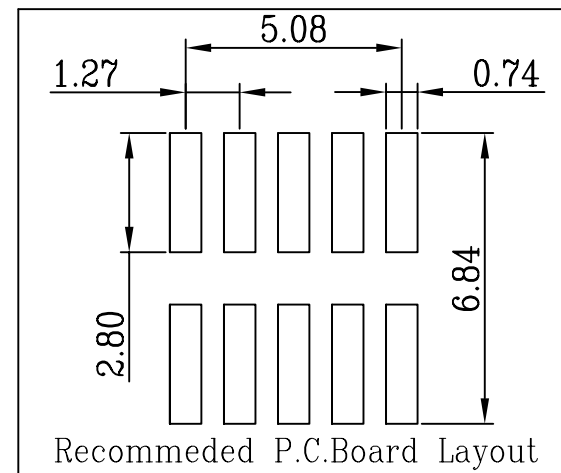
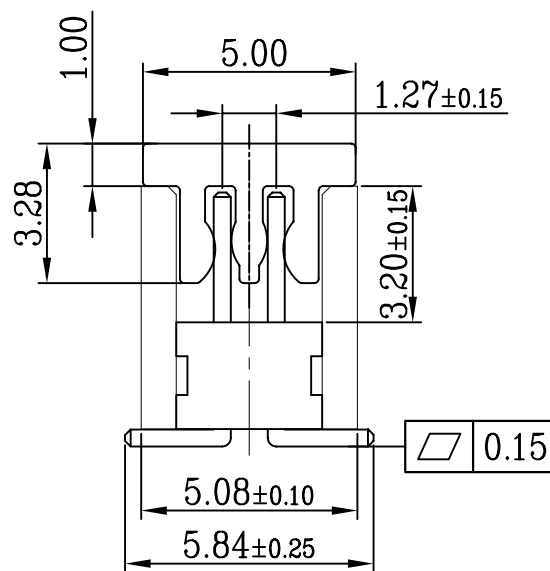
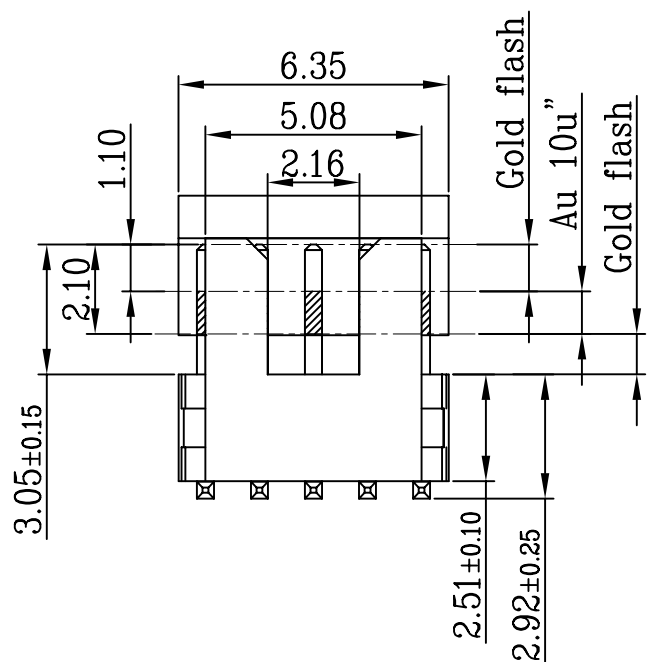

RoHS Compliant

TOLERANCES ARE



煜倫股份有限公司

www.morethanall.com

DRAWING BY CY

CHECKED BY GENIUS

UNIT / mm SCALE 1 : 1

DATE

SIZE A4

X. ± 0.30

.X ± 0.25

.XX ± 0.15

.XXX ± 0.05

ANG ±

PPOJECTION



ORDER INFORMATION

PAK-V29X30S01CR-2X05-LF

SERIES | | | | | LEADFREE
 180°SMT | | | | | REEL
 HIGH 2.92mm | | | | | CAP
 NON POST | | | | | SEMI GOLD FLASH
 CONTACT 3.05mm

DESCRIPTION:

