

Material:
 * Insulation:
 Glass filled Polyamide UL 94V-0
 Color Black
 * Contact: Copper alloy, t=0.2mm
 * Fixed Tab: Brass, t=0.2mm

DIM.A = 0.50 * No. of Spaces
 DIM.B = DIM.A + 3.0
 DIM.C = DIM.A + 2.0
 DIM.D = DIM.A + 0.5

△ * Available in 10 through 60 circuits

NP0526-S10PR-LF
 LEADFREE
 RoHS Compliant

MORETHANALL
 CONNECTORS
 ASSEMBLIES

PART NO. NP0526-S10PR-xxx

DWG NO. NP0526-S10PR-xxx

FILE NO.

CHECKED BY CY

DRAWING BY

TOLERANCES ARE

.X ± 0.2
 .XX ±
 .XXX ±
 AWG

DESCRIPTION:

煜倫股份有限公司

UNIT / mm

SCALE 1:1

PROJECTION



AREA



REVISIONS

HK

DATE

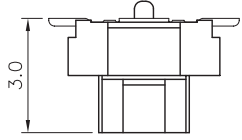
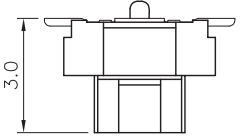
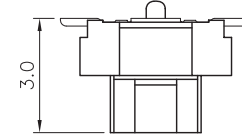
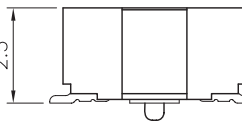
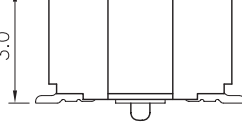
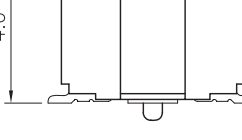
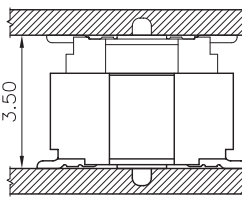
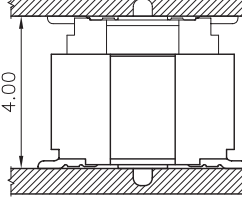
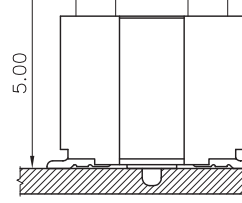
	1	2	3	4	5	6	7	8	9	0
J										
I										
H										
G										
F										
E										
D										
C										
B										
A										

Female	NP0526-S10PR-xxx	NP0526-S10PR-xxx	NP0526-S10PR-xxx
			
Male	NP0526-P25PR-xxx	NP0526-P30PR-xxx	NP0526-P40PR-xxx
			
Mating Height			

	PART NO. NP0526-S10PR-xxx		TOLERANCES ARE .X ± 0.2 .XX ± .XXX ± AWG	DESCRIPTION:				
	DWG NO. NP0526-S10PR-xxx				CHECKED BY CY	AREA	REVISIONS	HK
焯倫股份有限公司	FILE NO.		DRAWING BY					
	UNIT / mm	SCALE 1:1	PROJECTION 					

- NOTE :
- * Reel Material : HIPS
 - * Carrier Material : Clear, Conductive Polystyrene Alloy
 - * Cover Tape Material : Polyester
 - * Cover Tape Peel Strength : 0.1N – 1.3N
 - * Carrier camber is within 1mm in 100mm
 - * All dimensions meet EIA-481-2 & EIA-481-3 requirements.
 - * Quantity : 1000 PCS/Reel

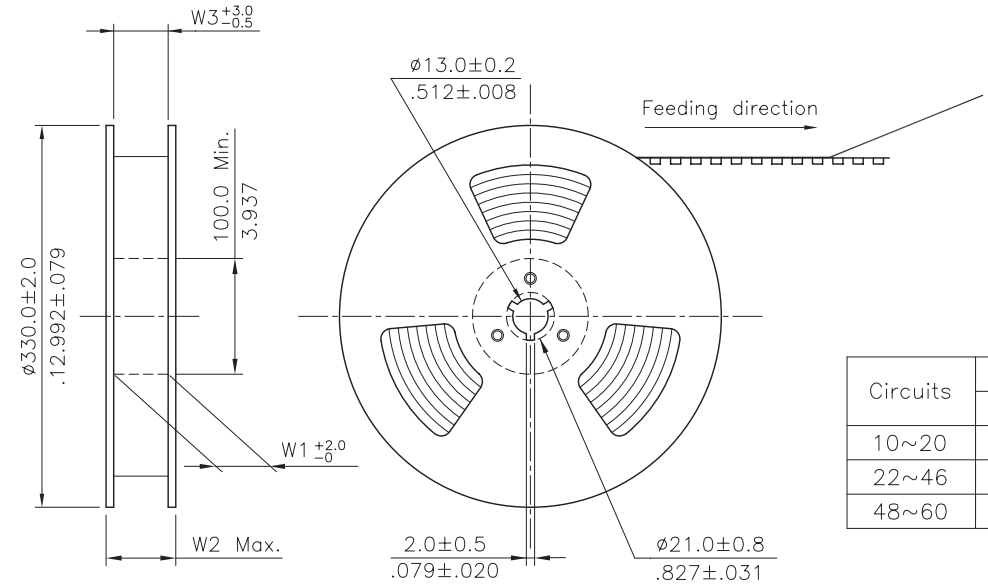

Circuits	Dimension					Packing (Reel/Caton)
	E	F	W1	W2	W3	
10~20	16.0(.630)	-	16.5(.650)	22.5(.886)	16.5(.650)	11
22~46	24.0(.945)	-	24.5(.965)	30.5(1.200)	24.5(.965)	9
48~60	32.0(1.260)	28.40(1.118)	32.5(1.280)	38.5(1.516)	32.5(1.280)	7

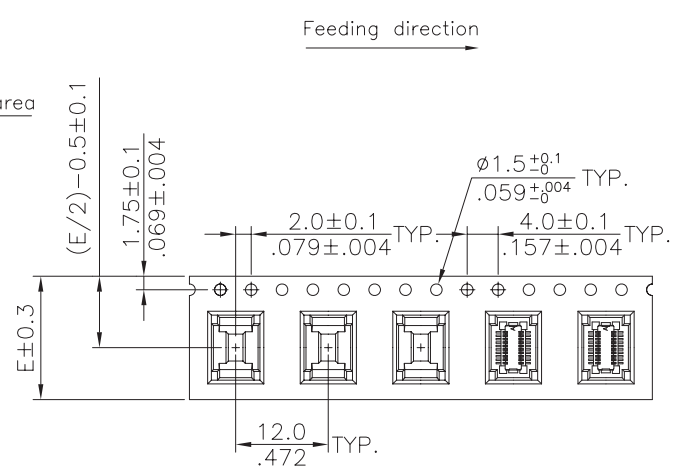
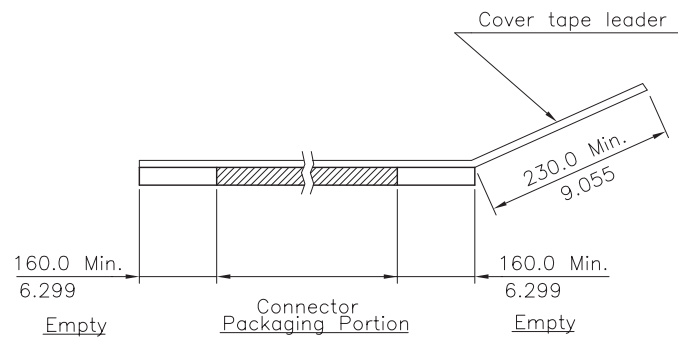

WIDTH : 16,24 mm Carrier

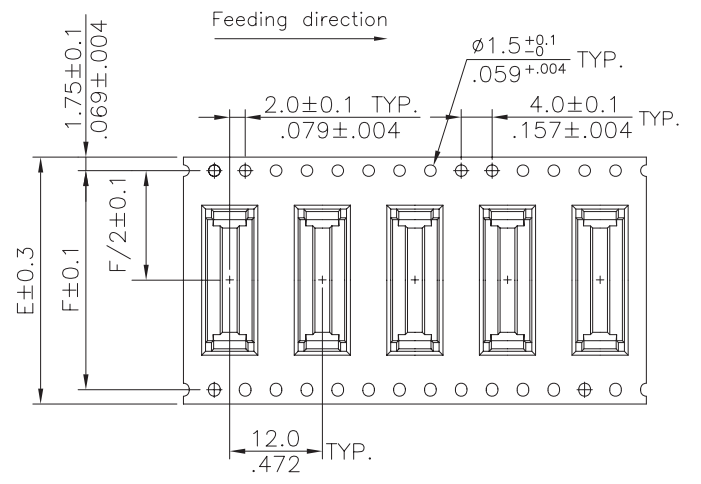

WIDTH : 32 mm Carrier

	PART NO. NP0526-S10PR-xxx		TOLERANCES ARE .X ± 0.2 .XX ± .XXX ± AWG	DESCRIPTION:				
	DWG NO. NP0526-S10PR-xxx						CHECKED BY CY	
焯倫股份有限公司	FILE NO.		DRAWING BY		AREA	REVISIONS	HK	DATE
	UNIT / mm	SCALE 1:1	PROJECTION					