

【NOTE】

- Lead co-planarity (Lead 평탄도) : ☆ Max 0.08mm (0.08mm 이하)
- After Re-flow lead co-planarity : ☆ Max 0.08mm (Reflow 후 평탄도 : ☆ 0.08mm 이하)
- 220℃ Lead co-planarity (220℃ Lead 평탄도) : Max 0.08mm (0.08mm 이하)
- ☆ = CTF (☆ 는 CTF 항목) / ★ = CTQ (★ 는 CTQ 항목)
- No rust, contamination, damage nor deformation effecting on function. (제품 기능 및 성능에 유해한 BURR, 변형, 휨, 이물질 등이 없을 것.)

【TABLE】

No.	PART	MATERIAL	FINISH
A	BASE INSULATOR	LCP S475	Black color
B	CONTACT TERMINAL	Corson alloy NKC286-H t:0.080mm	Nickel Barrier *Contact : Au 0.1~0.4µm over Nickel 1.5~5µm Lead : Au flash 0.05µm Min over Ni 1.5~5µm
C	FITTING NAIL	Phosphor Bronze C5210-H t:0.080mm	Sn 1.0~5.0µm over Nickel 1.0~5.0µm

【환경규제 준수】

(OQA-2049)에 지정된 환경관리 물질을 사용하지 말 것.

RoHS Compliant

TOLERANCES ARE

MORETHANALL
PCB CONNECTORS
Cable ASSEMBLIES
煜倫股份有限公司
www.morethanall.com

DRAWING BY	CY	X. ± 0.25
CHECKED BY	GENIUS	.X ± 0.20
UNIT / mm	SCALE 1 : 1	.XXX ±
DATE		ANG ±
SIZE	A4	PJECTION

照片框

ORDER INFORMATION

NP03514-S07XR-060-LF
SERIES | LEADFREE
60 WAY
REEL
NON POST
UNMATED HIGH 0.7mm
FEMALE

DESCRIPTION: BTB 0.35PITCH H=0.8mm RECEP'

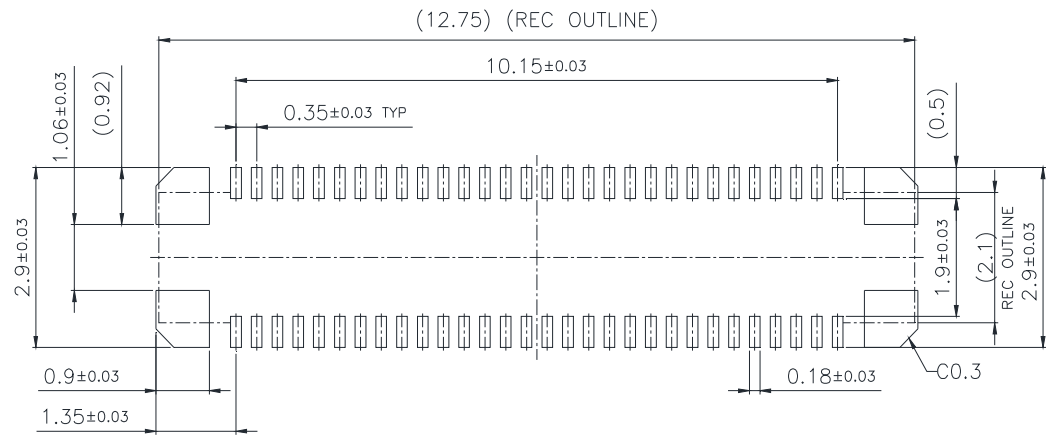

APPLICABLE P.C.B DIMENSION

<<Recommended window size of metal mask>>

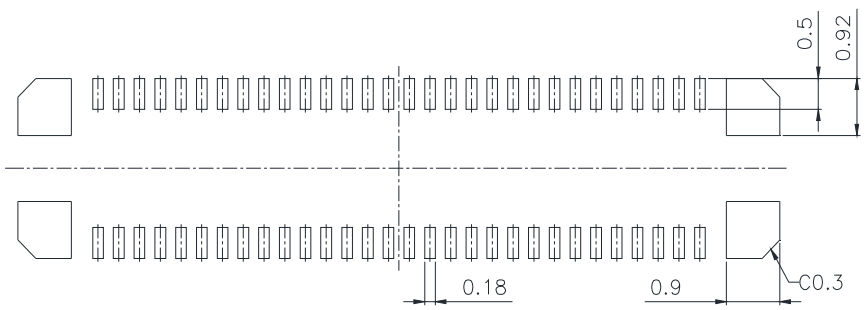

MASK (Thickness : 0.10mm)

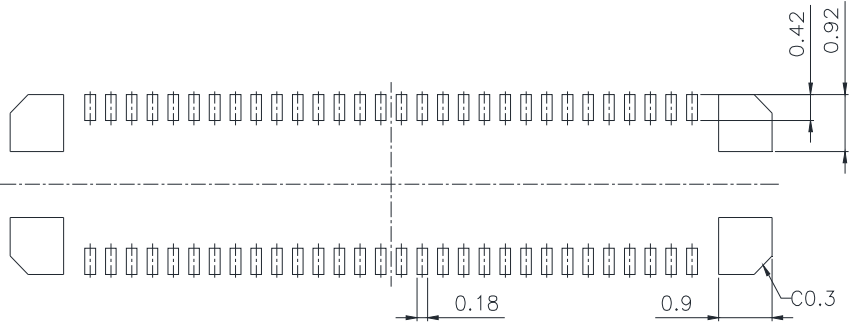

MASK (Thickness : 0.12mm)

RoHS Compliant

TOLERANCES ARE

照片框

ORDER INFORMATION



煜倫股份有限公司

www.morethanall.com

DRAWING BY CY

CHECKED BY GENIUS

UNIT / mm

SCALE 1 : 1

DATE

SIZE A4

PJECTION

X. ± 0.25
X. ± 0.20
.XX ± 0.10
.XXX ±
ANG ±

NP03514-S07XR-060-LF

SERIES REEL LEADFREE
NON POST 60 WAY
UNMATED HIGH 0.7mm
FEMALE

DESCRIPTION: BTB 0.35PITCH H=0.8mm RECEPT

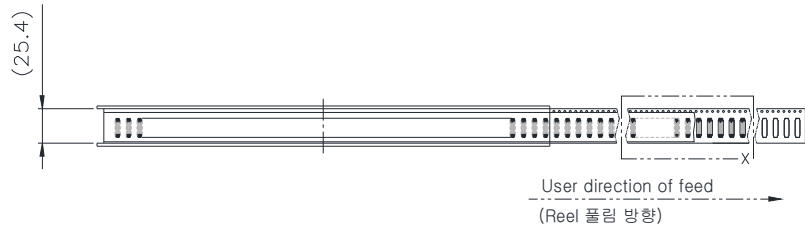

Scale 5:1

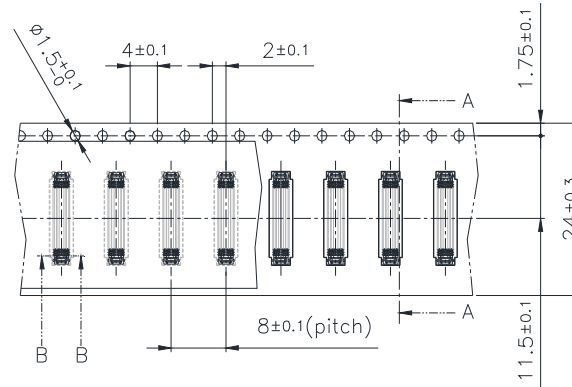

DETAIL X

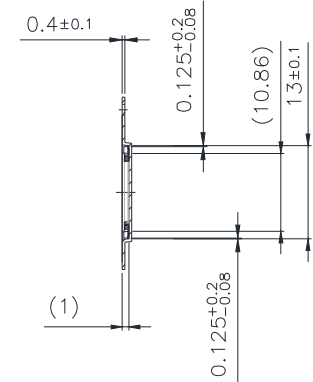

SECTION A-A

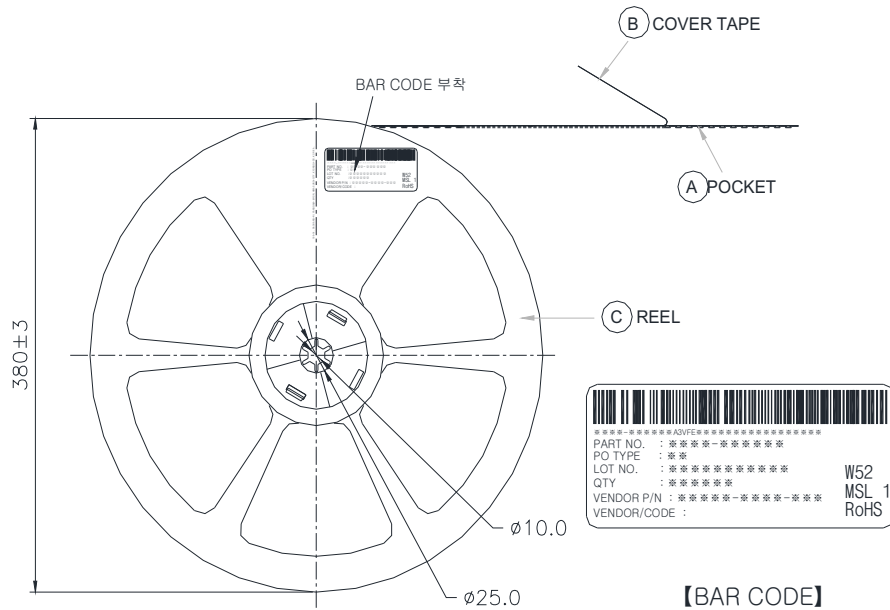

【BAR CODE】

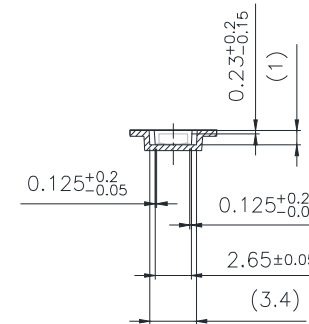

SECTION B-B (Scale 2:1)

【TABLE】

PART	(A) POCKET	(B) COVER TAPE	(C) REEL
MATERIAL	PS	PET	HIPS

RoHS Compliant

TOLERANCES ARE

MORETHANALL
PCB CONNECTORS
Cable ASSEMBLIES
煜倫股份有限公司

DRAWING BY CY

CHECKED BY GENIUS

UNIT / mm

SCALE 1:1

DATE

SIZE A4

X, ±
.X ± 0.40
.XX ± 0.30
.XXX ±
ANG ± 5°

P PROJECTION

照片框

ORDER INFORMATION

NP03514-S07XR-060-LF

SERIES

LEADFREE

60 WAY

REEL

NON POST

UNMATED HIGH 0.7mm

FEMALE

DESCRIPTION: BTB 0.35PITCH H=0.8mm RECEPTACLE PACK'G.

www.morethanall.com

【REFERENCE 1】(참조 1)

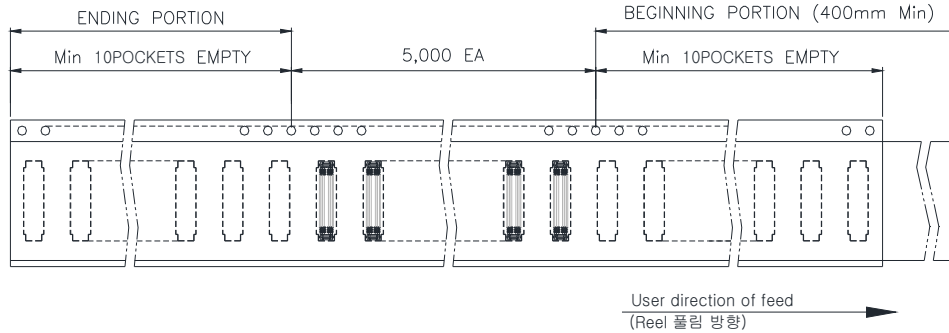

【REFERENCE 1】(참조 1)

- ▶ Peel strength of cover tape : 10~70gf (Cover 테이프 탈착강도 : 10~70gf)
- ▶ Peeling speed : 300mm/minute (탈착 속도 : 300mm/분)

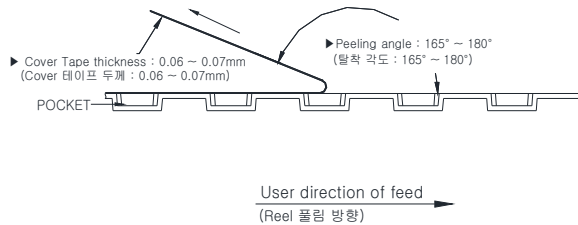

【REFERENCE 2】(참조 2)

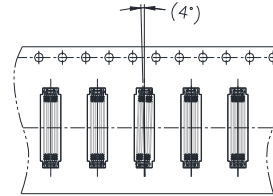

◆ EMOSS TAPE SPECIFICATION (표장 규격)

【REFERENCE 1】(참조 1)

- Quantity : 5,000ea / 1 Reel (수량 : 5,000ea / Reel)
- Beginning portion - Empty 10pockets min, Ending portion - Empty 10pockets min. (Reel 앞에서 10pockets 이상, 뒤에서 10pockets 이상 비움 것)
- It is thermal welding for connector post packaging method. (Connector 포장시 Cover tape 압착방식은 열용착 방식으로 한다.)
- Peel strength of cover tape : 10~70gf (Cover 테이프 강도 : 10~70gf)
- Peeling speed : 300mm/minute (속도 : 300mm/minute)
- Peeling angle : 165° ~ 180° (각도 : 165° ~ 180°)
- Cover Tape thickness : 0.06 ~ 0.07mm (Cover 테이프 두께 : 0.06 ~ 0.07mm)
- Confirm that Reel Cover Tape is treated with control material. Reel Cover Tape of static electricity (Reel Cover Tape 재전 처리 되어 있을 것.)
- The surface resistance must be in good condition. (control SPEC':1×10⁵~10⁹) (표면저항 양호할 것(관리 SPEC':1×10⁵~10⁹)
- Generation volume of static electricity : 100V and less (정전기 발생량 100V 이하 일것.)

ITEM (항 목)	표면 저항	정전기 발생량
Reel Cover Tape	1×10 ⁵ ~ 1×10 ⁹	100V
Carrier tape	1×10 ⁵ ~ 1×10 ⁹	100V

【REFERENCE 2】(참조 2)

- Product angle in pocket would be tilt : (4.0°) (Emboss 내 부품 뒤틀림각도 : (4.0°))

<< NOTE >>

- Reel 5,000ea packing. (1Reel 5,000ea 포장)
- Reel 포장된 제품을 실리카겔 삽입 후 진공 포장 한다.
- 진공포장 된 제품을 가스로 넣어서 Outer carton box 에 포장 한다 .
▷ 1 outer carton box : 5,000ea × 10reel = 50,000ea
- Outer carton box size (외곽 포장 치수) : 405(width) × 395(length) × 340(height)
- Reel - Adhesive of Bar-Code & label. (Bar-Code 및 label 부착)
- Outer box (외곽포장박스) - Box label , 유해물질보증식별표시.

【MATERIAL TABLE】

NO.	PART	MATERIAL
A	Outer carton box	Corrugated cardboard
B	Reel	HIPS
C	Vinyl	Vinyl
D	SILICAGEL	SILICAGEL

【OUTER PACKING】

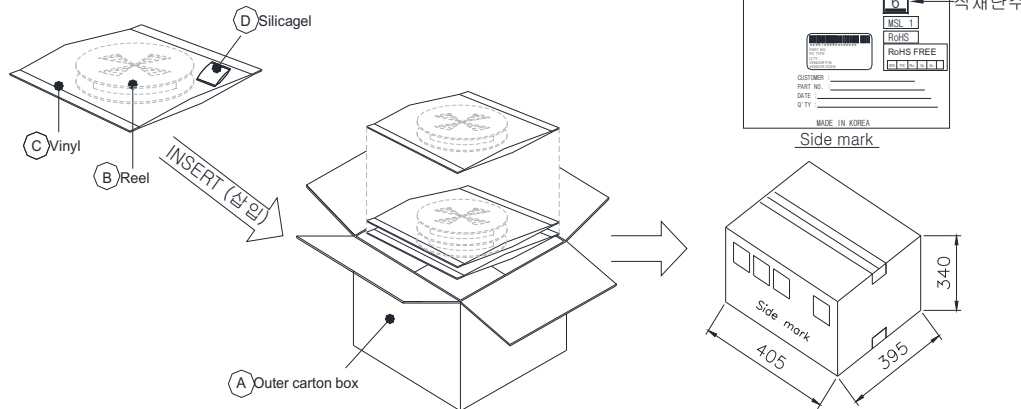

RoHS Compliant

TOLERANCES ARE

MORETHANALL
PCB CONNECTORS
Cable ASSEMBLIES

煜倫股份有限公司

www.morethanall.com

DRAWING BY CY

CHECKED BY GENIUS

UNIT / mm SCALE 1 : 1

DATE

SIZE A4 PPROJECTION

X, ±
.X ± 0.40
.XX ± 0.30
.XXX ±
ANG ± 5°

照片框

ORDER INFORMATION

NP03514-S07XR-060-LF

SERIES | LEADFREE
60 WAY
REEL
NON POST
UNMATED HIGH 0.7mm
FEMALE

DESCRIPTION: BTB 0.35PITCH H=0.8mm RECEPTACLE PACK'G.