

SECTION A-A (Scale 20:1)

[NOTE]

1. Lead co-planarity (Lead) : ☆ Max 0.08mm (0.08mm)
2. After Re-flow lead co-planarity : ☆ Max 0.08mm (Reflow : ☆ 0.08mm)
1. 220°C Lead co-planarity (220°C Lead) : Max 0.08mm (0.08mm)
4. ☆ = CTF / ★ = CTQ
5. No rust, contamination, damage nor deformation effecting on function.

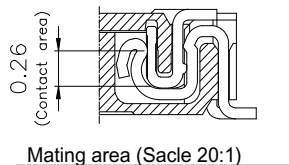
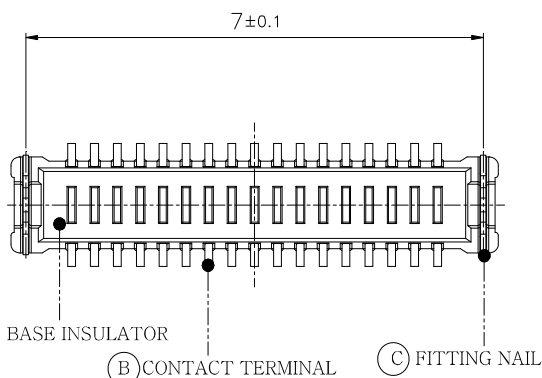

[TABLE]

No.	PART	MATERIAL	FINISH
A	BASE INSULATOR	LCP SZ6505	Black color
B	CONTACT TERMINAL	Phosphor Bronze C5210-EH t:0.080mm	Nickel Barrier ☆Contact : Au 0.1~0.4µm over Nickel 1.5~5µm Lead : Au flash 0.05µm Min over Ni 1.5~5µm
C	FITTING NAIL	Phosphor Bronze C5210-H t:0.080mm	Sn 1.0~5.0µm over Nickel 1.0~5.0µm

RoHS Compliant

TOLERANCES ARE

MORETHANALL
PCB CONNECTORS
Cable ASSEMBLIES
煜倫股份有限公司
www.morethanall.com

DRAWING BY CY
CHECKED BY GENIUS
UNIT / mm SCALE 1 : 1
DATE
SIZE A4 PPROJECTION

X, ±
.X ± 0.25
.XX ± 0.20
.XXX ± 0.10
ANG ±

照片框

ORDER INFORMATION

NP03514-P01XR-034-LF
SERIES | LEADFREE
34 WAY
REEL
NON POST
UNMATED HIGH 0.1mm
MALE

DESCRIPTION: BTB 0.35PITCH H=0.8mm PLUG

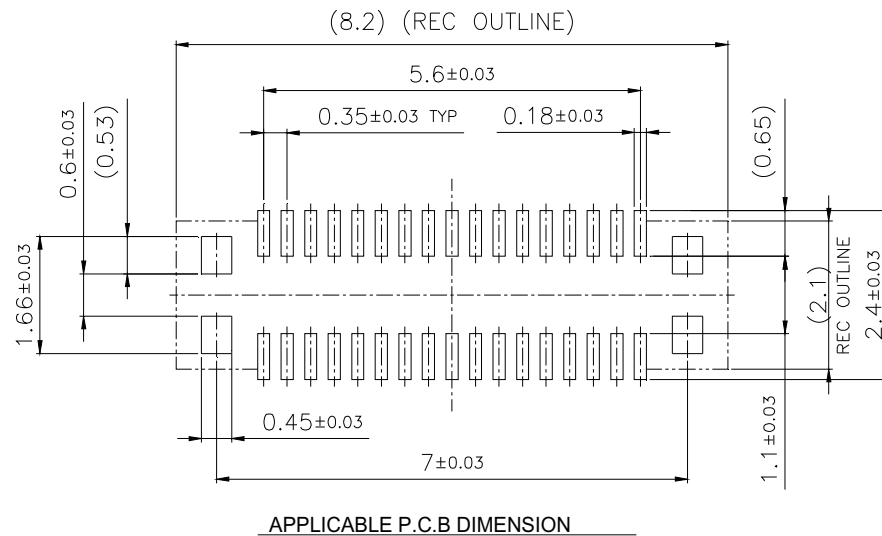

<<Recommended window size of metal mask>>

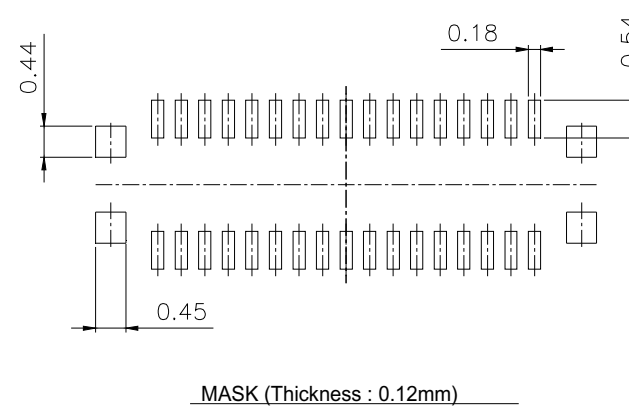
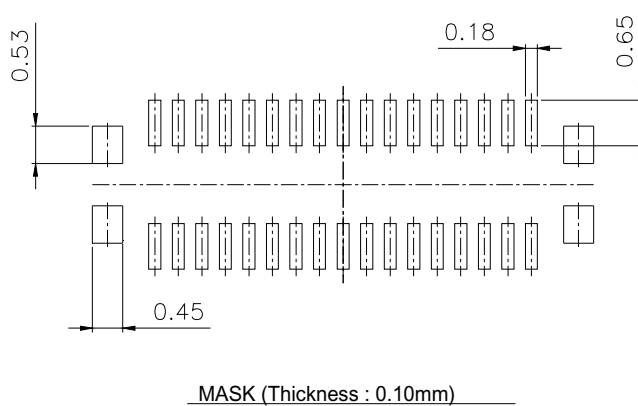

RoHS Compliant

TOLERANCES ARE

MORETHANALL
PCB CONNECTORS
Cable ASSEMBLIES
煜倫股份有限公司
www.morethanall.com

DRAWING BY CY	
CHECKED BY GENIUS	
UNIT / mm	SCALE 1 : 1
DATE	
SIZE A4	PPOJECTION

X, ±
.X ± 0.25
.XX ± 0.20
.XXX ± 0.10
ANG ±

照片框

ORDER INFORMATION

NP03514-P01XR-034-LF

SERIES	LEADFREE
	34 WAY
	REEL
	NON POST
	UNMATED HIGH 0.1mm
	MALE

DESCRIPTION: BTB 0.35PITCH H=0.8mm PLUG

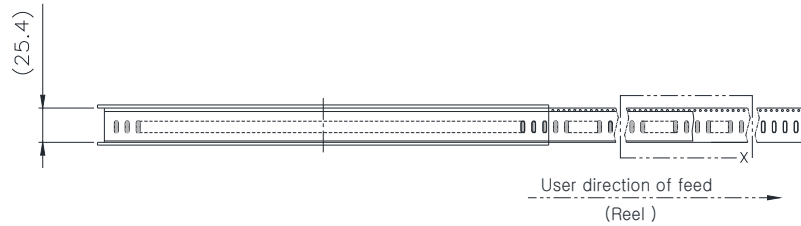

Scale 5:1

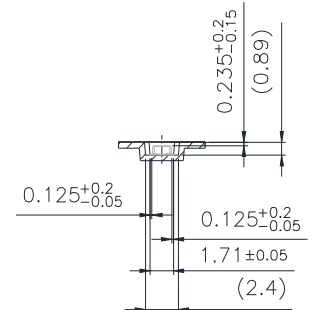
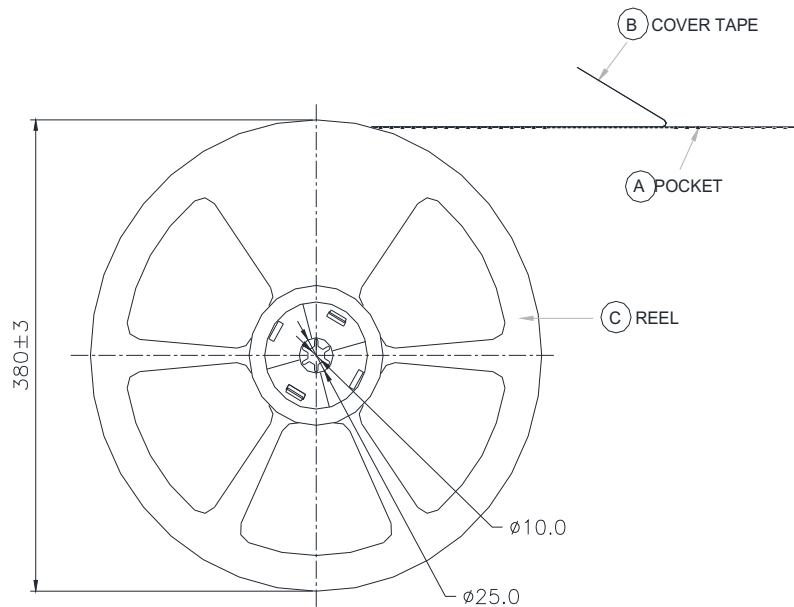
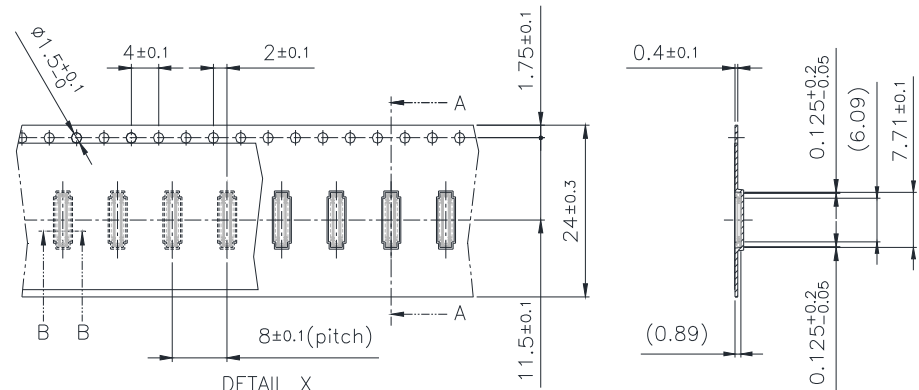

SECTION B-B (Scale 2:1)

RoHS Compliant

TOLERANCES ARE

MORETHANALL
PCB CONNECTORS
Cable ASSEMBLIES

DRAWING BY CY

X. \pm

CHECKED BY GENIUS

.X ± 0.40

UNIT / mm

SCALE 1:1

.XX ± 0.30

DATE

.XXX \pm

ANG $\pm 5^\circ$

照片框

ORDER INFORMATION

NP03514-P01XR-034-LF

SERIES

LEADFREE

34 WAY

REEL

NON POST

UNMATED HIGH 0.1mm

MALE

煜倫股份有限公司

www.morethanall.com

SIZE A4

PJECTION

DESCRIPTION:

【REFERENCE 1】

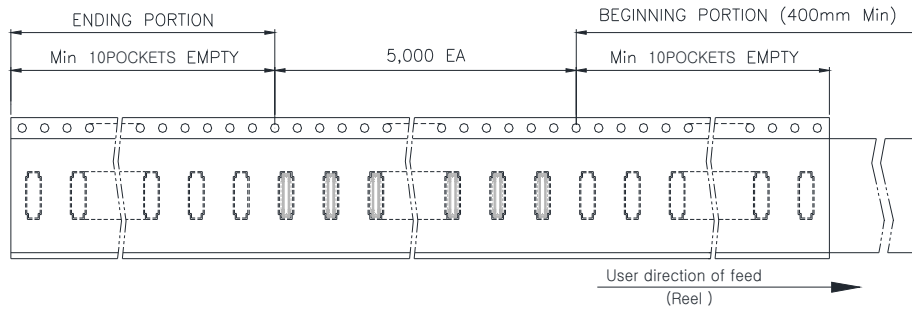

【REFERENCE 1】

- ▶ Peel strength of cover tape : 10~70gf
- ▶ Peeling speed : 300mm/minute

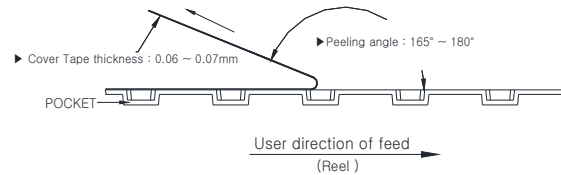

【REFERENCE 2】

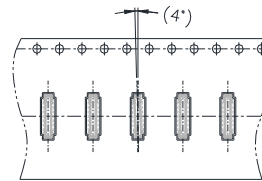

◆ EMBOSS TAPE SPECIFICATION

【REFERENCE 1】

- Quantity : 5,000ea / 1 Reel
- Beginning portion - Empty 10pockets min, Ending portion - Empty 10pockets min.
- It is thermal welding for connector post packaging method.
- Peel strength of cover tape : 10~70gf
- Peeling speed : 300mm/minute
- Peeling angle : 165° ~ 180°
- Cover Tape thickness : 0.06 ~ 0.07mm
- Confirm that Reel Cover Tape is treated with control material Reel Cover Tape of static electricity
- The surface resistance must be in good condition. (control SPEC: $1 \times 10^5 \sim 10^9$)
- Generation volume of static electricity : 100V and less

ITEM		
Reel Cover Tape	$1 \times 10^5 \sim 1 \times 10^9$	100V
Carrier tape	$1 \times 10^5 \sim 1 \times 10^9$	100V

【REFERENCE 2】

- Product angle in pocket would be tilt : (4.0°)

<< NOTE >>

- Reel 5,000ea packing. (1Reel 5,000ea)
- Reel.
- Outer carton box .
 - ▷ 1 outer carton box : 5,000ea × 10reel = 50,000ea
- Outer carton box size : 405(width) × 395(length) × 340(height)
- Reel - Adhesive of Bar-Code & label.
- Outer box - Box label .

【MATERIAL TABLE】

NO.	PART	MATERIAL
A	Outer carton box	Corrugated cardboard
B	Reel	HIPS
C	PP bag	PP bag
D	SILICAGEL	SILICAGEL

【OUTER PACKING】

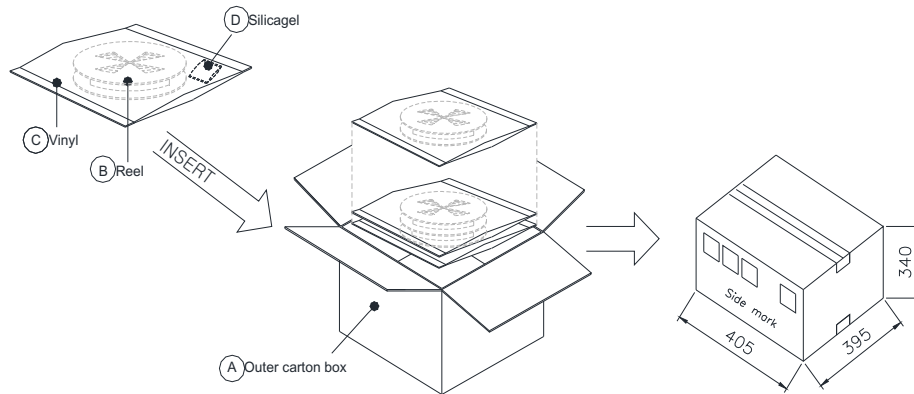

RoHS Compliant

TOLERANCES ARE

MORETHANALL
PCB CONNECTORS
Cable ASSEMBLIES

DRAWING BY CY

CHECKED BY GENIUS

UNIT / mm

SCALE 1 : 1

DATE

SIZE A4

X, ±
.X ± 0.40
.XX ± 0.30
.XXX ±
ANG ± 5°

PJECTION

照片框

煜倫股份有限公司

www.morethanall.com

ORDER INFORMATION

NP03514-P01XR-034-LF

SERIES | REEL | 34 WAY | LEADFREE
NON POST
UNMATED HIGH 0.1mm
MALE

DESCRIPTION: