

SECTION A-A (Scale 20:1)

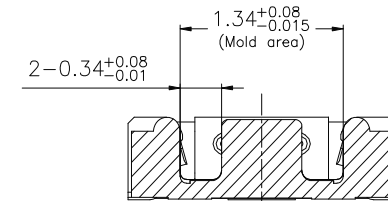

SECTION B-B (Scale 20:1)

RoHS Compliant

TOLERANCES ARE

MORETHANALL
PCB CONNECTORS
Cable ASSEMBLIES

DRAWING BY CY

X, ±
.X ± 0.25
.XX ± 0.20
.XXX ± 0.10
ANG ±

CHECKED BY GENIUS

UNIT / mm SCALE 1 : 1

DATE

SIZE A4

PJECTION

照片框

ORDER INFORMATION

NP03513-S07XR-040-LF

SERIES | | | | LEADFREE
40 WAY
REEL
NON POST
UNMATED HIGH 0.7mm
FEMALE

煜倫股份有限公司

www.morethanall.com

DESCRIPTION: BTB 0.35mm PITCH H:0.8mm RECEPTACLE (FEMALE)

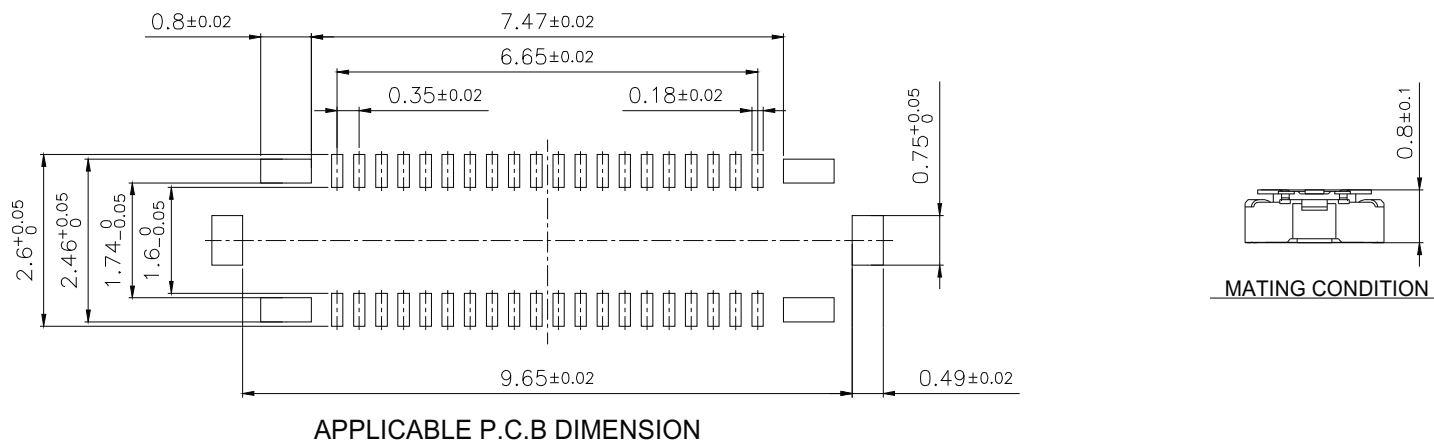

[NOTE]

1. No rust, contamination, damage nor deformation effecting on function.
(제품 기능 및 성능에 유해한 Burr, 변형, 휨, 이물질 등이 없을 것.)
2. Lead co-planarity (Lead 평탄도) : ☆ Max 0.08mm (0.08mm 이하)
3. ☆ = CTF (☆ 는 CTF 항목) / ★ = CTQ (★는 CTQ 항목)
4. Before and After Re-flow lead co-planarity
: ☆ Max 0.08mm (Re-flow 전,후 평탄도 : 0.08 이하)
5. 220℃ Lead co-planarity (220℃ Lead 평탄도) : Max 0.08mm (0.08mm 이하)
- ⚠ 6. Header DIM' 7.82 이상 , Socket DIM' 7.81 이하로 관리 할 것.
(Header Minimum 과 Socket Maximum 시 간섭되지 않을것.)
- ⚠ 7. 별도 구분을 위해 "* or 기타 식별표시" 등 기재할수 있다.
EX) O5* (3월5일*) or O5. (3월5일.)

[TABLE]

| No. | PART | MATERIAL | FINISH |
|-----|------------------|---------------------------------------|--|
| A | BASE INSULATOR | LCP UX101 | Black Color (UL 94V-0) |
| B | CONTACT TERMINAL | Phosphor Bronze C5240-EH t:0.060mm | ☆ Contact : Au 0.1μm Min over Nickel 1.0μm Min Lead : Au 0.05μm Min over Nickel 1.0μm Min |
| C | FITTING NAIL | Copper Alloy C7035-TM04 t:0.060mm | ☆ Contact : Au 0.1μm Min over Nickel 1.0μm Min Lead : Au 0.05μm Min over Nickel 1.0μm Min |

RoHS Compliant

TOLERANCES ARE

MORETHANALL
PCB CONNECTORS
Cable ASSEMBLIES

煜倫股份有限公司

www.morethanall.com

DRAWING BY CY

CHECKED BY GENIUS

UNIT / mm

SCALE 1 : 1

DATE

SIZE A4

X, ±
.X ± 0.25
.XX ± 0.20
.XXX ± 0.10
ANG ±

PPOJECTION

照片框

ORDER INFORMATION

NP03513-S07XR-040-LF

SERIES | REEL | LEADFREE
40 WAY
NON POST
UNMATED HIGH 0.7mm
FEMALE

DESCRIPTION:

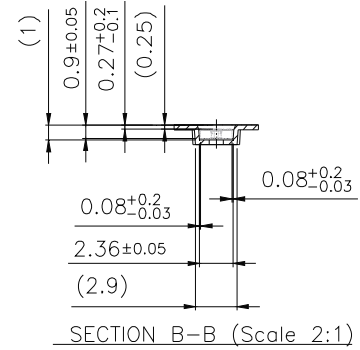
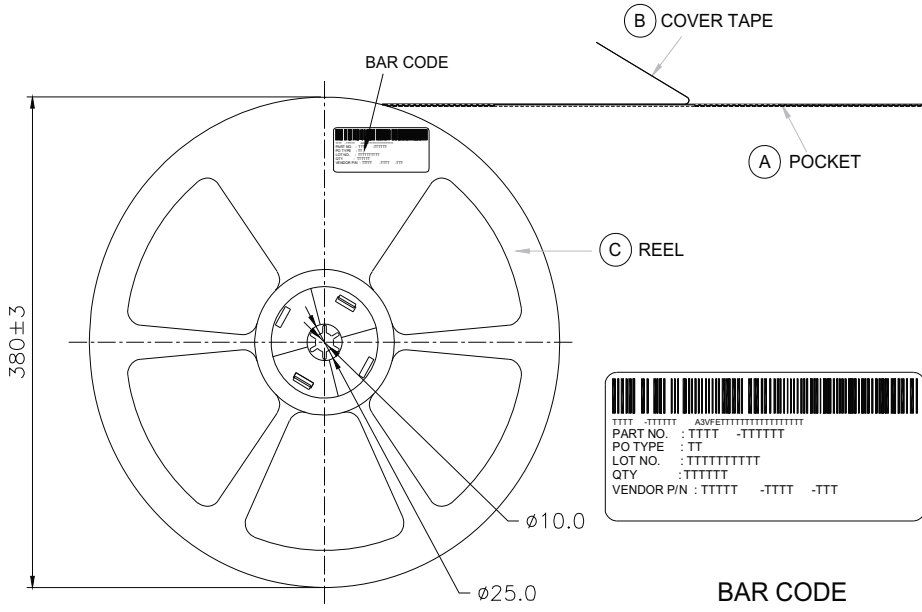
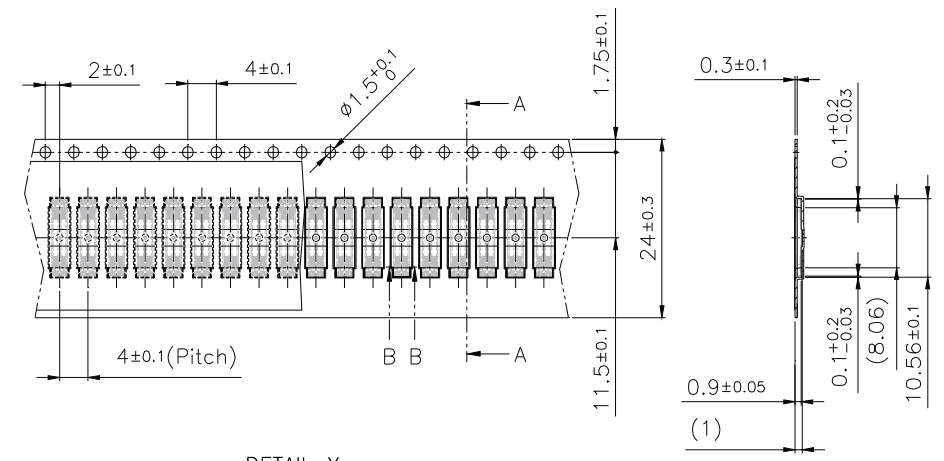
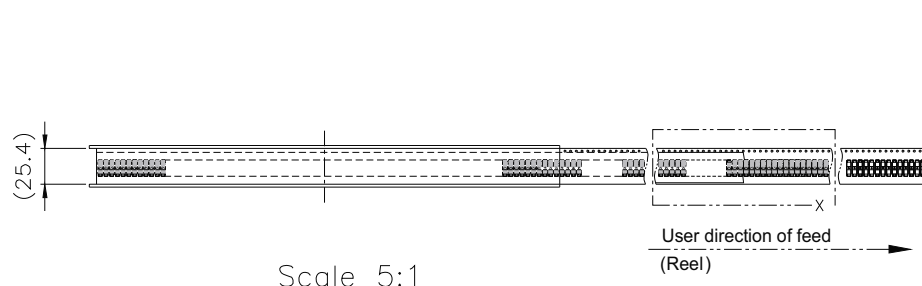

RoHS Compliant

TOLERANCES ARE



DRAWING BY CY

CHECKED BY GENIUS

UNIT / mm SCALE 1:1

DATE

SIZE A4

X, ±
.X ± 0.40
.XX ± 0.30
.XXX ±
ANG ± 5°

PJECTION

照片框

ORDER INFORMATION

NP03513-S07XR-040-LF

SERIES REEL NON POST UNMATED HIGH 0.7mm FEMALE LEADFREE 40 WAY

DESCRIPTION:

煜倫股份有限公司

www.morethanall.com

【REFERENCE 1】 (참조 1)

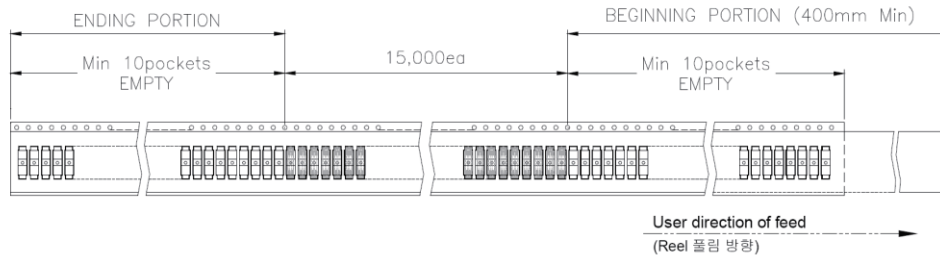

【REFERENCE 1】 (참조 1)

- ▶ Peel strength of cover tape : 10~70gf (Cover 테이프 탈착강도 : 10~70gf)
- ▶ Peeling speed : 300mm/minute (탈착 속도 : 300mm/분)

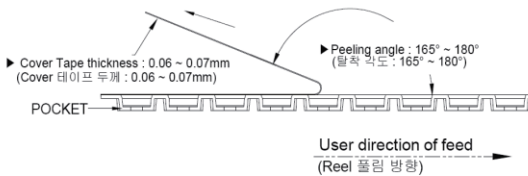

【REFERENCE 2】 (참조 2)

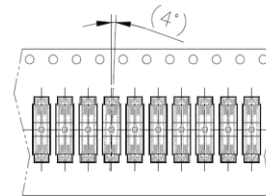

【OUTER PACKING】

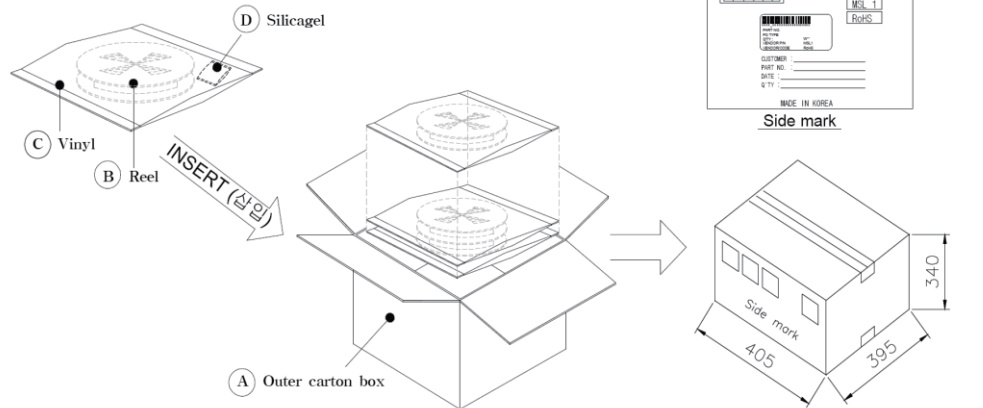

◆ EMOSS TAPE SPECIFICATION (포장 규격)

【REFERENCE 1】 (참조 1)

- Quantity : 15,000ea / 1 Reel (수량 : 15,000개 / 릴)
- Beginning portion - Empty 10pockets min, Ending portion - Empty 10pockets min. (Reel 앞에서 10pockets 이상, 뒤에서 10pockets 이상 비울 것.)
- It is thermal welding for connector post packaging method. (Connector 포장시 Cover tape 압착방식은 열융착 방식으로 한다.)
- Peel strength of cover tape : 10~70gf (Cover 테이프 강도 : 10~70gf)
- Peeling speed : 300mm/minute (속도 : 300mm/minute)
- Peeling angle : 165° ~ 180° (각도 : 165° ~ 180°)
- Cover Tape thickness : 0.06 ~ 0.07mm (Cover 테이프 두께 : 0.06 ~ 0.07mm)
- Confirm that Reel Cover Tape is treated with control material Reel Cover Tape of static electricity. (표면저항 양호할 것(관리 SPEC' : 1×10⁵~1×10⁹))
- The surface resistance must be in good condition. (control SPEC' : 1×10⁵~1×10⁹)
- Generation volume of static electricity : 100V and less (정전기 발생량 100V 이하 일것.)

| ITEM (항 목) | 표면 저항 | 정전기 발생량 |
|-----------------|---------------------------------------|---------|
| Reel Cover Tape | 1×10 ⁵ ~ 1×10 ⁹ | 100V |
| Carrier tape | 1×10 ⁵ ~ 1×10 ⁹ | 100V |

【REFERENCE 2】 (참조 2)

- Product angle in pocket would be tilt : (4.0°) (Emboss 내 부품 기울림각도 : (4.0°))

<< NOTE >>

- Reel 15,000ea packing. (1릴 15,000개 포장)
- Reel 포장된 제품을 실리카겔 삽입 후 진공 포장 한다.
- 진공포장 된 제품을 가로로 눕혀서 Outer carton box 에 포장 한다.
▶ 1 outer carton box : 15,000ea × 10reel = 150,000ea
- Outer carton box size (외곽 포장 치수) : 405(width) × 395(length) × 340(height)
- Reel - Adhesive of Bar-Code & label.(Bar-Code 및 label 부착)
- Outer box (외곽포장박스) - Adhesive of Box label (라벨부착)

【MATERIAL TABLE】

| NO. | PART | MATERIAL |
|-----|------------------|----------------------|
| A | Outer carton box | Corrugated cardboard |
| B | Reel | HIPS |
| C | Vinyl | Vinyl |
| D | SILICAGEL | SILICAGEL |

RoHS Compliant

TOLERANCES ARE

MORETHANALL
PCB CONNECTORS
Cable ASSEMBLIES
煜倫股份有限公司

DRAWING BY CY

CHECKED BY GENIUS

UNIT / mm

SCALE 1 : 1

DATE

SIZE A4

PJECTION

X, ±
.X ± 0.40
.XX ± 0.30
.XXX ±
ANG ± 5°

照片框

ORDER INFORMATION

NP03513-S07XR-040-LF
SERIES REEL LEADFREE
40 WAY
NON POST
UNMATED HIGH 0.7mm
FEMALE

DESCRIPTION:

www.morethanall.com