

Fitting nail Contact area "A" (Scale 20:1)

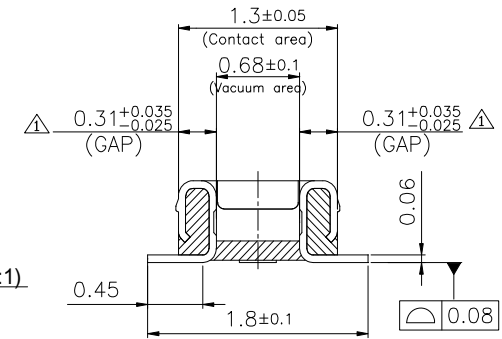

SECTION A-A (Scale 20:1)

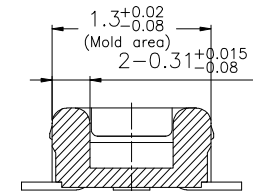
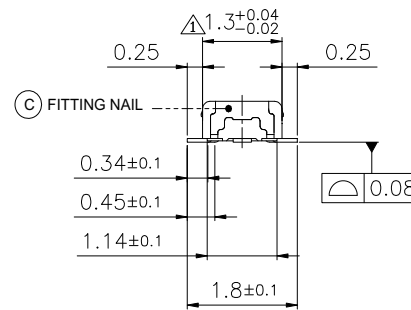

SECTION B-B (Scale 20:1)

RoHS Compliant

TOLERANCES ARE

MORETHANALL
PCB CONNECTORS
Cable ASSEMBLIES

DRAWING BY CY

X ±
.X ± 0.25
.XX ± 0.20
.XXX ± 0.10
ANG ±

CHECKED BY GENIUS

UNIT / mm SCALE 1 : 1

DATE

SIZE A4

PJECTION

照片框

ORDER INFORMATION

NP03513-P01XR-040-LF

SERIES					LEADFREE
					40 WAY
					REEL
					NON POST
					UNMATED HIGH 0.1mm
					MALE

DESCRIPTION: BTB 0.35mm PITCH H=0.8mm PLUG (MALE)

煜倫股份有限公司

www.morethanall.com

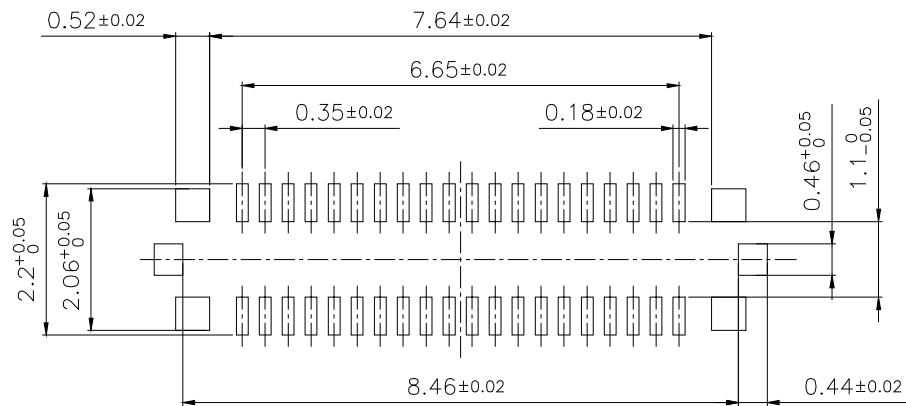

(APPLICABLE P.C.B DIMENSION)

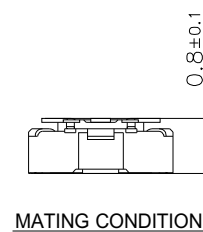

[NOTE]

1. No rust, contamination, damage nor deformation effecting on function.
(제품 기능 및 성능에 유해한 Burr, 변형, 휨, 이물질 등이 없을 것.)
2. Lead co-planarity (Lead 평탄도) : ☆ Max 0.08mm (0.08mm 이하)
3. ☆ = CTF (☆ 는 CTF 항목) / ★ = CTQ (★는 CTQ 항목)
4. Before and After Re-flow lead co-planarity
: ☆ Max 0.08mm (Re-flow 전,후 평탄도 : 0.08 이하)
5. 220℃ Lead co-planarity (220℃ Lead 평탄도) : Max 0.08mm (0.08mm 이하)
6. 별도 구분을 위해 " * or 기타 식별표시 " 등 기재할수 있다.
EX) O5* (3월5일*) or O5. (3월5일.)

【TABLE】

No.	PART	MATERIAL	FINISH
A	BASE INSULATOR	LCP HA475	Black Color (UL 94V-0)
B	CONTACT TERMINAL	Phosphor Bronze C5210-H t:0.060mm	☆ Contact : Au 0.1 μ m Min over Nickel 1.0 μ m Min Lead : Au 0.05 μ m Min over Nickel 1.0 μ m Min
C	FITTING NAIL	Copper Alloy C7035-TM04 t:0.060mm	☆ Contact : Au 0.1 μ m Min over Nickel 1.0 μ m Min Lead : Au 0.05 μ m Min over Nickel 1.0 μ m Min

RoHS Compliant

TOLERANCES ARE

MORETHANALL
PCB CONNECTORS
Cable ASSEMBLIES

煜倫股份有限公司

www.morethanall.com

DRAWING BY CY

CHECKED BY GENIUS

UNIT / mm

SCALE 1 : 1

DATE

SIZE A4

X, \pm
.X \pm 0.25
.XX \pm 0.20
.XXX \pm 0.10
ANG \pm

PPOJECTION

照片框

ORDER INFORMATION

NP03513-P01XR-040-LF

SERIES | REEL | LEADFREE
40 WAY
NON POST
UNMATED HIGH 0.1mm
MALE

DESCRIPTION:

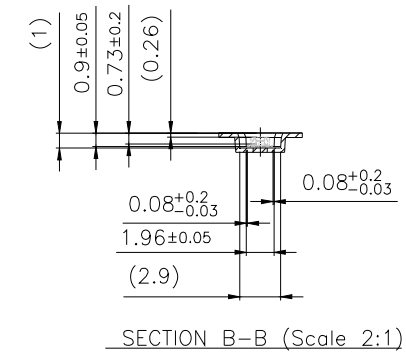
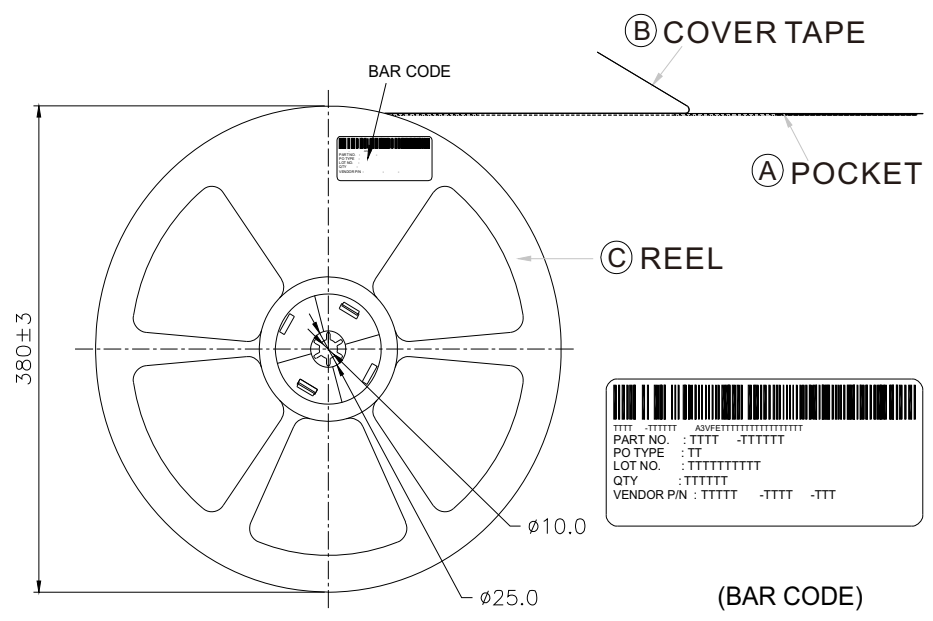
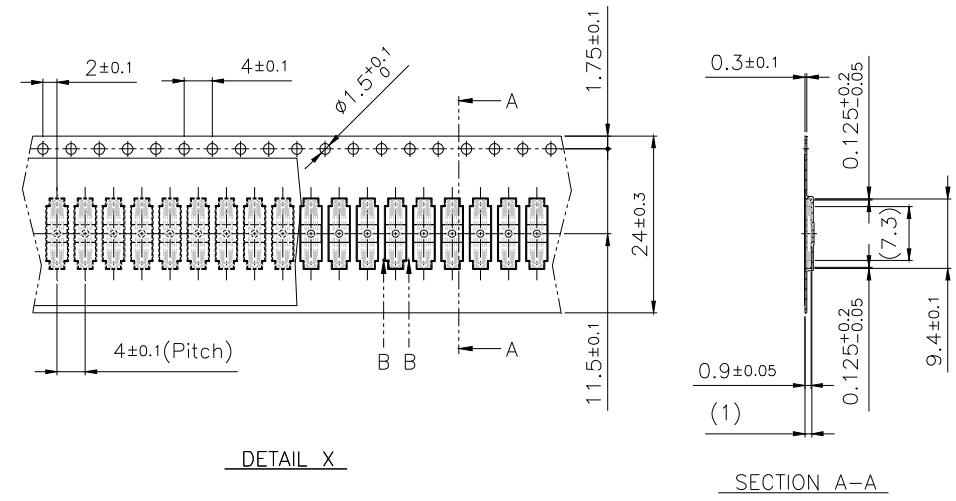
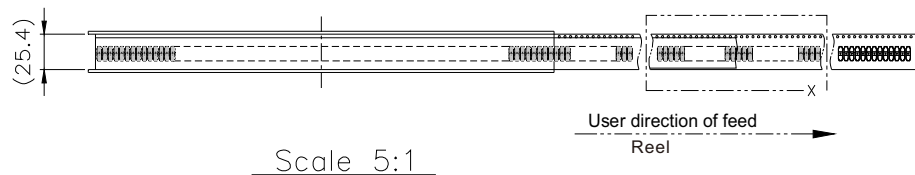

【TABLE】

PART	(A) POCKET	(B) COVER TAPE	(C) REEL
MATERIAL	PET	PET	HIPS

RoHS Compliant

TOLERANCES ARE

MORETHANALL
PCB CONNECTORS
Cable ASSEMBLIES
煜倫股份有限公司
www.morethanall.com

DRAWING BY	CY	X. ±
CHECKED BY	GENIUS	.X ± 0.40
UNIT / mm	SCALE 1:1	.XX ± 0.30
DATE		.XXX ±
SIZE A4	PJECTION	ANG ± 5°



ORDER INFORMATION

NP03513-P01XR-040-LF
SERIES | LEADFREE
40 WAY
REEL
NON POST
UNMATED HIGH 0.1mm
MALE

DESCRIPTION:

【REFERENCE 1】 (참조 1)

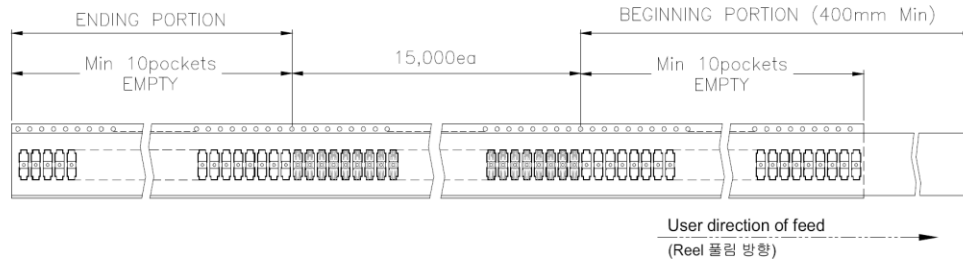

【REFERENCE 1】 (참조 1)

- ▶ Peel strength of cover tape : 10~70gf (Cover 테이프 탈착강도 : 10~70gf)
- ▶ Peeling speed : 300mm/minute (탈착 속도 : 300mm/분)

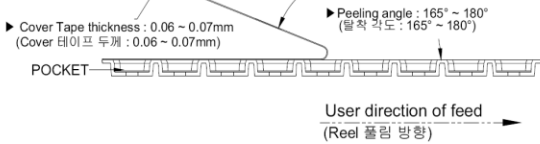

【REFERENCE 2】 (참조 2)

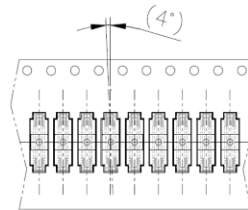

【OUTER PACKING】

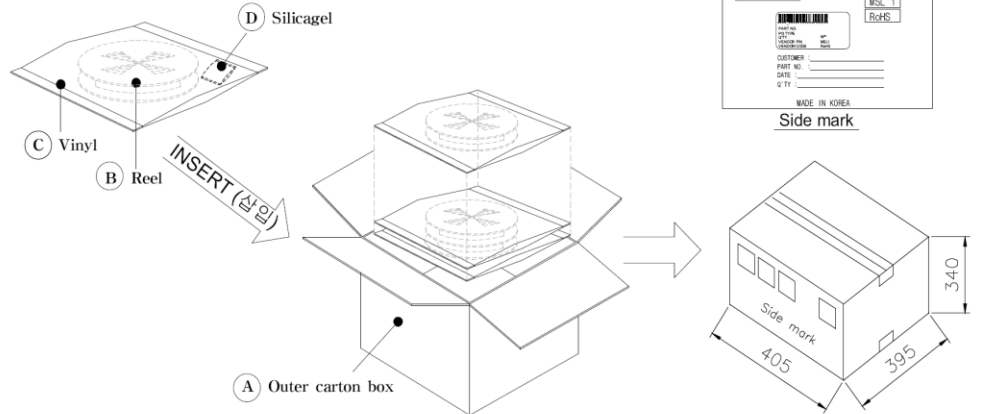

◆ EMBOSS TAPE SPECIFICATION (포장 규격)

【REFERENCE 1】 (참조 1)

- Quantity : 15,000ea / 1 Reel (수량 : 15,000개 / 릴)
- Beginning portion - Empty 10pockets min, Ending portion - Empty 10pockets min. (Reel 앞에서 10pockets 이상, 뒤에서 10pockets 이상 비울 것)
- It is thermal welding for connector post packaging method. (Connector 포장시 Cover tape 압착방식은 열융착 방식으로 한다.)
- Peel strength of cover tape : 10~70gf (Cover 테이프 강도 : 10~70gf)
- Peeling speed : 300mm/minute (속도 : 300mm/minute)
- Peeling angle : 165° ~ 180° (각도 : 165° ~ 180°)
- Cover Tape thickness : 0.06 ~ 0.07mm (Cover 테이프 두께 : 0.06 ~ 0.07mm)
- Confirm that Reel Cover Tape is treated with control material Reel Cover Tape of static electricity. (Reel Cover Tape 재전 처리 되어 있을 것.)
- The surface resistance must be in good condition, (control SPEC' : $1 \times 10^5 \sim 1 \times 10^9$) (표면저항 양호할 것 (관리 SPEC' : $1 \times 10^5 \sim 1 \times 10^9$))
- Generation volume of static electricity : 100V and less (정전기 발생량 100V 이하 일것.)

ITEM (항 목)	표면 저항	정전기 발생량
Reel Cover Tape	$1 \times 10^5 \sim 1 \times 10^9$	100V
Carrier tape	$1 \times 10^5 \sim 1 \times 10^9$	100V

【REFERENCE 2】 (참조 2)

- Product angle in pocket would be tilt : (4.0°) (Emboss 내 부품 뒤틀림각도 : (4.0°))

<< NOTE >>

- Reel 15,000ea packing. (1릴 15,000개 포장)
- Reel 포장된 제품을 실리카겔 삽입 후 진공 포장 한다.
- 진공포장 된 제품을 가로로 눕혀서 Outer carton box 에 포장 한다.
▷ 1 outer carton box : 15,000ea × 10reel = 150,000ea
- Outer carton box size (외곽 포장 치수) : 405(width) × 395(length) × 340(height)
- Reel - Adhesive of Bar-Code & label. (Bar-Code 및 label 부착)
- Outer box (외곽포장박스) - Adhesive of Box label (라벨부착)

PART NO. : _____

 PO TYPE : _____

 QTY : _____

 W** : _____

 MSL1 : _____

 RoHS : _____

 CUSTOMER : _____

 PART NO. : _____

 DATE : _____

 QTY : _____

【MATERIAL TABLE】

NO.	PART	MATERIAL
A	Outer carton box	Corrugated cardboard
B	Reel	HIPS
C	Vinyl	Vinyl
D	SILICAGEL	SILICAGEL

RoHS Compliant

TOLERANCES ARE

MORETHANALL

 PCB CONNECTORS

 Cable ASSEMBLIES

煜倫股份有限公司

www.morethanall.com

DRAWING BY CY

 CHECKED BY GENIUS

 UNIT / mm SCALE 1 : 1

 DATE

 SIZE A4 PPROJECTION

X, ±

 .X ± 0.40

 .XX ± 0.30

 .XXX ±

 ANG ± 5°

照片框

ORDER INFORMATION

NP03513-P01XR-040-LF

 SERIES LEADFREE

 REEL 40 WAY

 NON POST

 UNMATED HIGH 0.1mm

 MALE

DESCRIPTION: