

SECTION A-A (Scale 20:1)

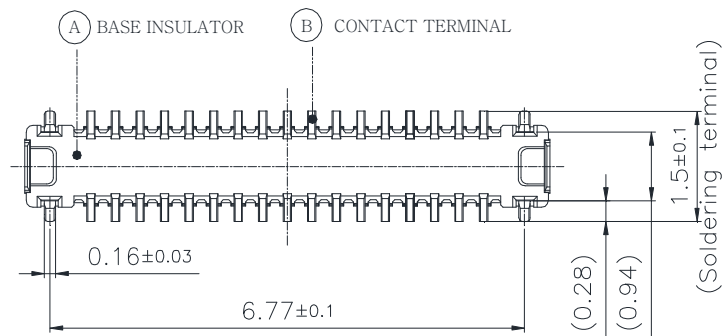

【TABLE】

No.	PART	MATERIAL	FINISH
A	BASE INSULATOR	LCP S475	Black Color (UL 94V-0)
B	CONTACT TERMINAL	Phosphor Bronze C5210-EH t:0.050mm	Nickel Barrier ☆Contact : Au 0.1~0.5μm over Nickel 1~6μm Lead : Au 0.05μm Min over Nickel 1~6μm
C	FITTING NAIL	Copper Alloy NKC286-EH t:0.070mm	△ Contact : Au 0.1μm Min over Nickel 1~6μm Lead : Au 0.03μm Min over Nickel 1~6μm

RoHS Compliant

TOLERANCES ARE

MORETHANALL
PCB CONNECTORS
Cable ASSEMBLIES

DRAWING BY CY

CHECKED BY GENIUS

UNIT / mm

SCALE 1 : 1

DATE

SIZE A4

X, ±
.X ± 0.25
.XX ± 0.20
.XXX ± 0.10
ANG ±

PJECTION

照片框

ORDER INFORMATION

NP03511-P01XR-034-LF

SERIES | REEL | LEADFREE
NON POST
UNMATED HIGH 0.1mm
MALE

DESCRIPTION: BTB 0.35mm PITCH H=0.6mm PLUG (MALE)

煜倫股份有限公司

www.morethanall.com

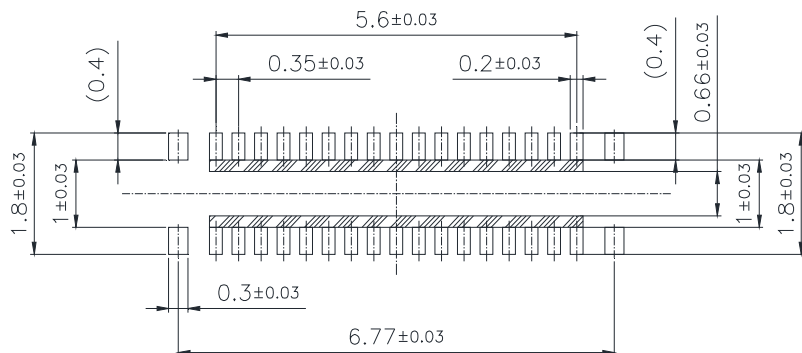

: INSULATION AREA

【 APPLICABLE P.C.B DIMENSION 】

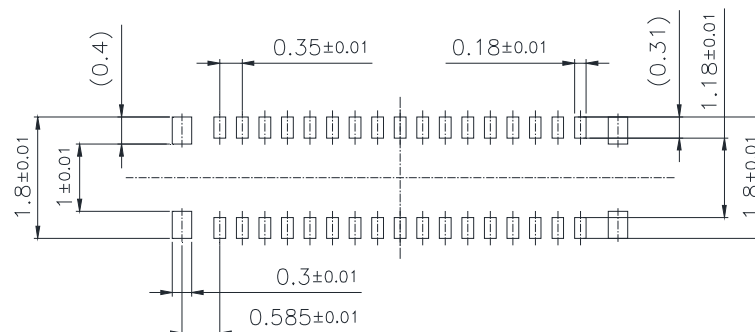

【 RECOMMEND METAL MASK PATTERN 】

(Metal Mask thickness : When 100 μ m)

(Terminal opening ratio : 70%)

(Metal part opening ratio : 70%)

【NOTE】

- No rust, contamination, damage nor deformation effecting on function.
(제품 기능 및 성능에 유해한 Burr, 변형, 휨, 이물질 등이 없을 것.)
- Lead co-planarity (Lead 평탄도) : ☆ Max 0.08mm (0.08mm 이하)
- ☆ = CTF (☆ 는 CTF 항목) / ★ = CTQ (★는 CTQ 항목)
- Before and After Re-flow lead co-planarity : ☆ Max 0.08mm
(Reflow 전,후 평탄도 : 0.08 이하)
- Window ratio is calculated by dividing window size of metal masking by the original mounting pad.
(윈도우 비율은 원본의 패드에 금속마스크의 크기를 분할하여 계산 함.)
- 220°C Lead co-planarity (220°C Lead 평탄도) : Max 0.08mm (0.08mm 이하)

RoHS Compliant

TOLERANCES ARE

MORETHANALL
PCB CONNECTORS
Cable ASSEMBLIES
煜倫股份有限公司
www.morethanall.com

DRAWING BY CY		X. ± .X ± 0.25 .XX ± 0.20 .XXX ± 0.10 ANG ±
CHECKED BY GENIUS		
UNIT / mm	SCALE 1 : 1	
DATE		
SIZE A4	PJECTION	

照片框

ORDER INFORMATION

NP03511-P01XR-034-LF
SERIES REEL NON POST UNMATED HIGH 0.1mm MALE
LEADFREE 34 WAY

DESCRIPTION: BTB 0.35mm PITCH H=0.6mm PLUG (MALE)



Scale 5:1

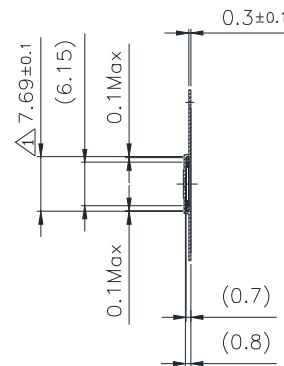

SECTION A-A

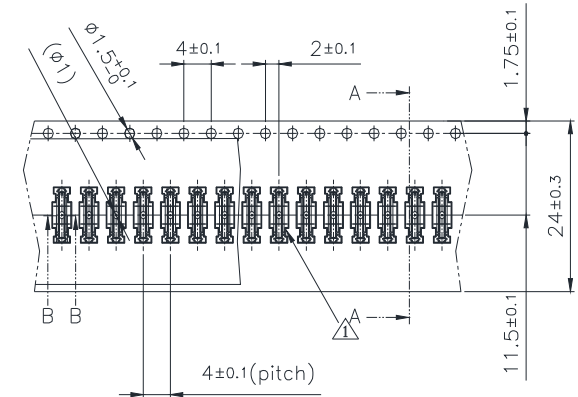

DETAIL X

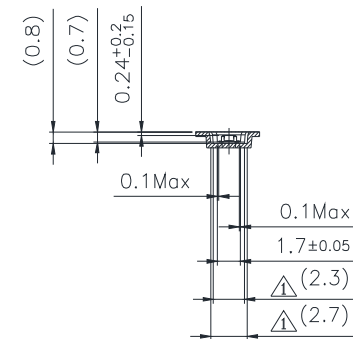
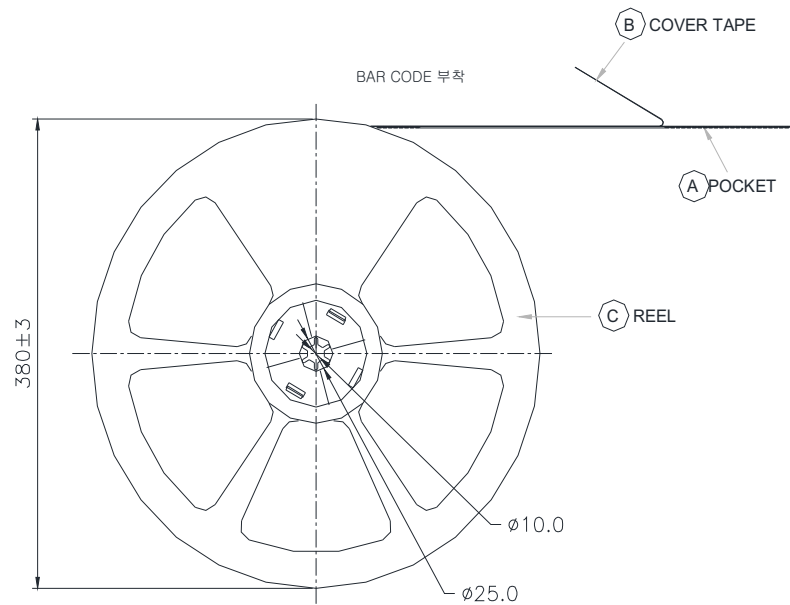

SECTION B-B (Scale 2:1)

RoHS Compliant

TOLERANCES ARE

MORETHANALL
PCB CONNECTORS
Cable ASSEMBLIES

DRAWING BY CY

X ±

CHECKED BY GENIUS

.X ± 0.25

UNIT / mm

SCALE 1:1

.XX ± 0.20

DATE

.XXX ± 0.10

ANG ±

SIZE A4

PJECTION

照片框

ORDER INFORMATION

NP03511-P01XR-034-LF

SERIES REEL NON POST UNMATED HIGH 0.1mm MALE

LEADFREE
34 WAY

DESCRIPTION: BTB 0.35mm PITCH H=0.6mm PLUG (MALE) PACK'G

煜倫股份有限公司

www.morethanall.com

【REFERENCE 1】(참조 1)

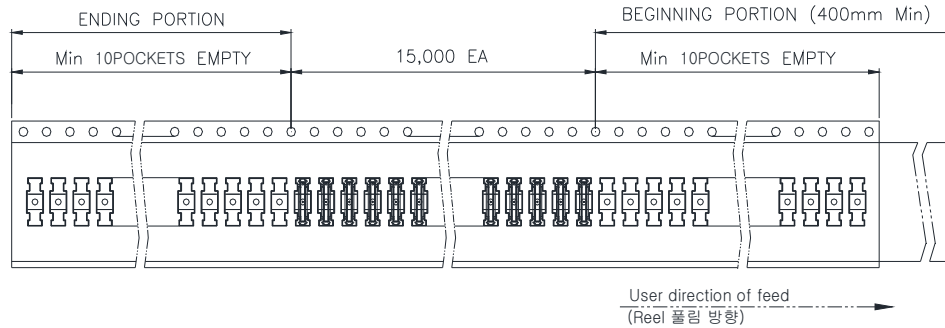

【REFERENCE 1】(참조 1)

- ▶ Peel strength of cover tape : 10~70gf (Cover 테이프 탈착강도 : 10~70gf)
- ▶ Peeling speed : 300mm/minute (탈착 속도 : 300mm/분)

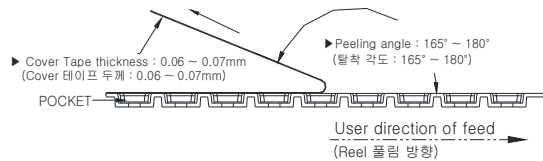

【REFERENCE 2】(참조 2)

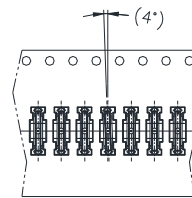

【OUTER PACKING】

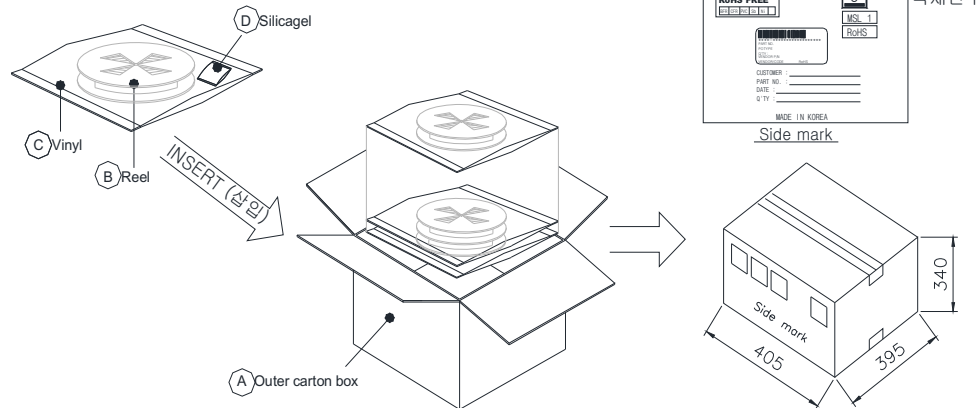

◆ EMBOSS TAPE SPECIFICATION (포장 규격)

【REFERENCE 1】(참조 1)

- Quantity : 15,000ea / 1 Reel (수량 : 15,000ea / Reel)
- Beginning portion - Empty 10pockets min, Ending portion - Empty 10pockets min.
(Reel 앞에서 10pockets 이상, 뒤에서 10pockets 이상 비울 것)
- It is thermal welding for connector post packaging method.
(Connector 포장시 Cover tape 압착방식은 열융착 방식으로 한다.)
- Peel strength of cover tape : 10~70gf (Cover 테이프 강도 : 10~70g)
- Peeling speed : 300mm/minute (속도 : 300mm/minute)
- Peeling angle : 165° ~ 180° (각도 : 165° ~ 180°)
- Cover Tape thickness : 0.06 ~ 0.07mm (Cover 테이프 두께 : 0.06 ~ 0.07mm)
- Confirm that Reel Cover Tape is treated with control materia I Reel Cover Tape of static electricity
(Reel Cover Tape 재전 처리 되어 있을 것.)
- The surface resistance must be in good condition. (control S PEC: 1×10⁵~10⁹)
(표면저항 양호할 것(관리 SPEC: 1×10⁵~10⁹))
- Generation volume of static electricity : 100V and less (정전기 발생량 100V 이하 일것.)

ITEM (항 목)	표면 저항	정전기 발생량
Reel Cover Tape	1×10 ⁵ ~ 1×10 ⁹	100V
Carrier tape	1×10 ⁵ ~ 1×10 ⁹	100V

【REFERENCE 2】(참조 2)

- Product angle in pocket would be tilt : (4.0°) (Emboss 내 부품뒤뜸각도: (4.0°))

<< NOTE >>

- Reel 15,000ea packing. (1Reel 15,000ea 포장)
- Reel 포장된 제품을 실리카겔 삽입 후 진공 포장 한다.
- 진공포장 된 제품을 가로로 눕혀서 Outer carton box 에 포장 한다 .
▶ 1 outer carton box : 15,000ea × 10reel = 150,000ea
- Outer carton box size (외곽 포장 치수) : 405(width) × 395(length) × 340(height)
- Reel - Adhesive of Bar-Code & label. (Bar-Code 및 label 부착)
- Outer box (외곽포장박스) - Box label (라벨 부착)

 PART NO. : _____
 QTY : _____
 VENDOR/PIN : _____
 VENDOR/CODE : _____
 CUSTOMER : _____
 PART NO. : _____
 DATE : _____
 QTY : _____

【MATERIAL TABLE】

NO.	PART	MATERIAL
A	Outer carton box	Corrugated cardboard
B	Reel	HIPS
C	Vinyl	Vinyl
D	SILICAGEL	SILICAGEL

RoHS Compliant



煜倫股份有限公司

www.morethanall.com

DRAWING BY CY
 CHECKED BY GENIUS
 UNIT / mm SCALE 1 : 1
 DATE
 SIZE A4 PPROJECTION

TOLERANCES ARE

X, ±
 .X ± 0.25
 .XX ± 0.20
 .XXX ± 0.10
 ANG ±

照片框

ORDER INFORMATION

NP03511-P01XR-034-LF
 SERIES REEL LEADFREE
 34 WAY
 NON POST
 UNMATED HIGH 0.1mm
 MALE

DESCRIPTION: BTB 0.35mm PITCH H=0.6mm PLUG (MALE) PACK'G