

DATE CODE
SEE NOTES 4

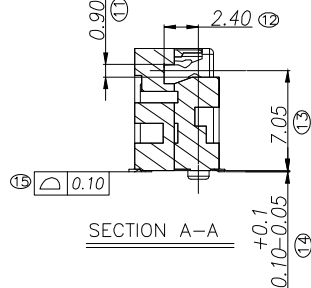

SECTION A-A

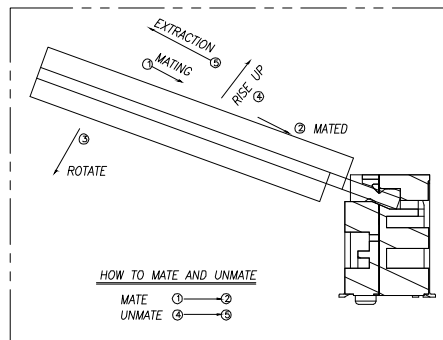
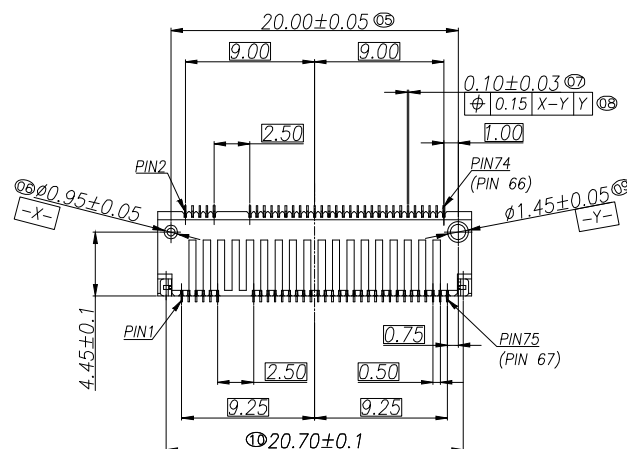
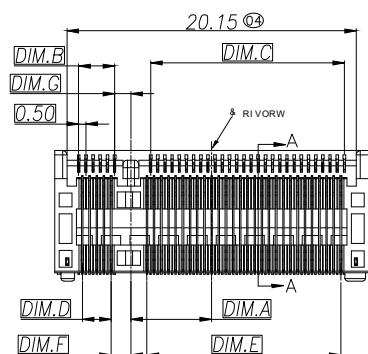
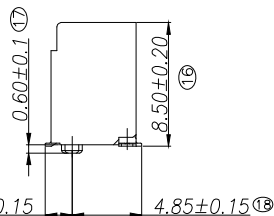

NOTES:

1.MATERIAL:

- 1.1.HOUSING: HIGH TEMPERATURE THERMOPLASTIC,UL94V-0,COLOR:BLACK
- 1.2.CONTACTS: COPPER ALLOY;
- 1.3.PEG: STAINLESS STEEL.

2.REFLOW SOLDER CAPABLE TO 260°C.

3.FINISH:

CONTACT: GOLD(SEE TABLE) PLATED ON CONTACT AREA AND GOLD FLASH SOLDER AREA. 50u" MIN NICKEL UNDERPLATING OVERALL.
PEG: 80u" MIN.MATTE-TIN PLATED ON SOLDERING AREA.
50u" MIN. NICKEL UNDERPLATING.

4. DATE CODE : YYWWDLX

YY: YEAR (09: 2009)

WW: WEEK (25: THE 25TH WEEK)

D: DAY (1~7: SUNDAY~SATURDAY)

L: LINE NUMBER OF ASSEMBLY (A: LINE A)

X: D OR N (D: DAY; N: NIGHT)

5.CONNECTOR ACTUAL PIN QUANTITY IS 67,AS THE KEY TAKING OUT 8 PINS.

NGFF-W85R-0760	KEY A	+6.625	1.5	14.5	1.0	14.5	1.125	1.375
NGFF-W85R-5809	KEY M	-6.125	14.0	2.0	14.0	1.5	1.125	1.375
NGFF-W85R-2344	KEY E	2.625	5.5	10.5	5.0	10.5	1.375	1.125
NGFF-W85R-1156	KEY B	5.625	2.5	13.5	2.0	13.5	1.375	1.125
PART NO.	KFY NAMF	DIM A	DIM B	DIM C	DIM D	DIM E	DIM F	DIM G

RoHS Compliant

TOLERANCES ARE

MORETHANALL
PCB CONNECTORS
Cable ASSEMBLIES

煜倫股份有限公司

www.morethanall.com

DRAWING BY CY

CHECKED BY GENIUS

UNIT / mm SCALE 1 : 1

DATE

SIZE A4

X, ±

.X ±

.XX ±

.XXX ±

ANG ±

PJECTION

照片框

ORDER INFORMATION

NGFF-W85R-xyy-LF

SERIES LEADFREE

1156:11+56 WAY

2344:23+44 WAY

5809:58+09 WAY

0760:07+60 WAY

REEL

DESCRIPTION:

EMBOSS WIDTH 44mm,SLOT FORWARD,AWM-815-XXXX

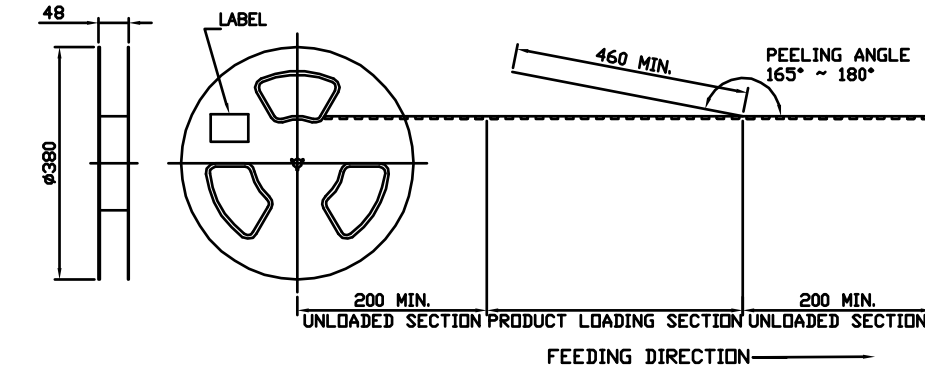

NOTES :

- MATERIAL :
COVER TAPE : ANTISTATIC P.S T=0.05±0.01 ,COLOR:CLEAR
CARRIER TAPE : ANTISTATIC P.S T=0.40±0.10,COLOR:BLACK
REEL : PS UL94V-0
CARTON: CORRUGATED FIBER
- DIMENSION :
REEL : SEE DRAWING
SHIPPING BOX: 385X385X295mm
- QUANTITY : SEE TABLE
- PEELING RESISTANCE : 10gf~130gf (for 12~56mm)
- PEELING SPEED : 300mm/MINUTES

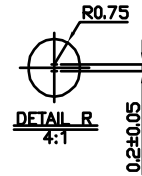
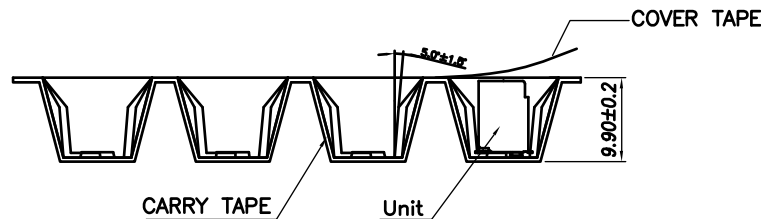
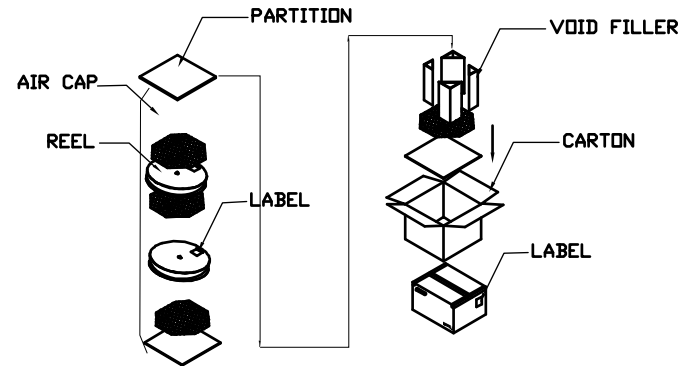
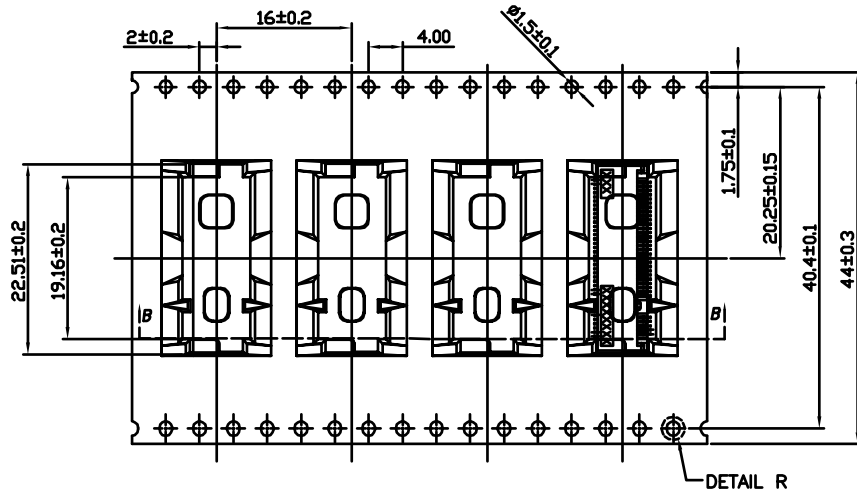

5.315KG	4.037KG	500	5	2500	NGFF-W85R-1156
GROSS WEIGHT	NET WEIGHT	PCS/ REEL	REEL/ CARTON	PCS/ CARTON	PART NUMBER

RoHS Compliant

TOLERANCES ARE

MORETHANALL
PCB CONNECTORS
Cable ASSEMBLIES

DRAWING BY CY

X, ±

CHECKED BY GENIUS

.X ±

UNIT / mm

SCALE 1 : 1

.XX ±

DATE

.XXX ±

ANG ±

SIZE A4

P PROJECTION

照片框

ORDER INFORMATION

NGFF-W85R-xyyy-LF

SERIES

LEADFREE

90°SMT

HIGH 8.5mm

1156:11+56 WAY

2344:23+44 WAY

5809:58+09 WAY

0760:07+60 WAY

REEL

DESCRIPTION:

煜倫股份有限公司

www.morethanall.com