

MATERIAL

Insulator : LCP UL94-V0 BLACK
Contact Pin : Brass

PLATING SPECIFICATION

CONTACT:
40~60u"Nickel Under plating over all
1u"Gold Plating on solder area

SMT TAB:

40~60u"Nickel Under plating over all
100~130u" Matte Tin Plating on solder area

SPECIFICATION

Current Rate : 0.5A PER PIN
Voltage Rate : 50V AC/DC
Withstand voltage : 200V AC for one minute
Insulation Resistance : 500MΩMin.
Contact Resistance : 20mΩMax
适用SMT制程温度: 260°C±5°C 3~5s

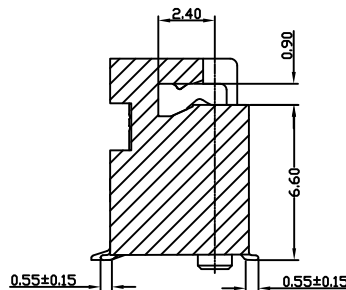
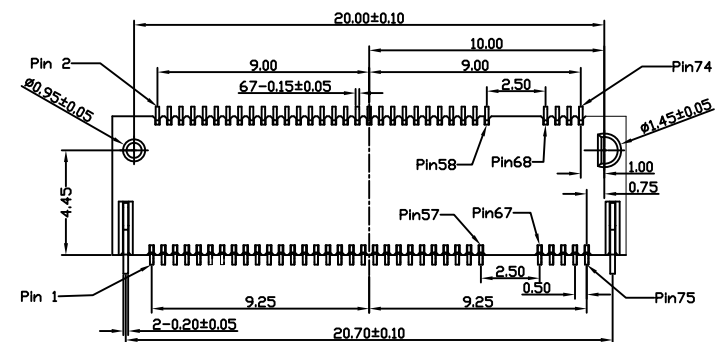
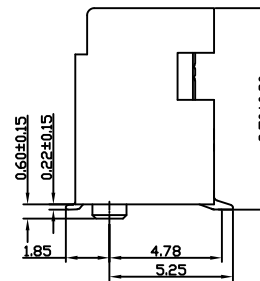
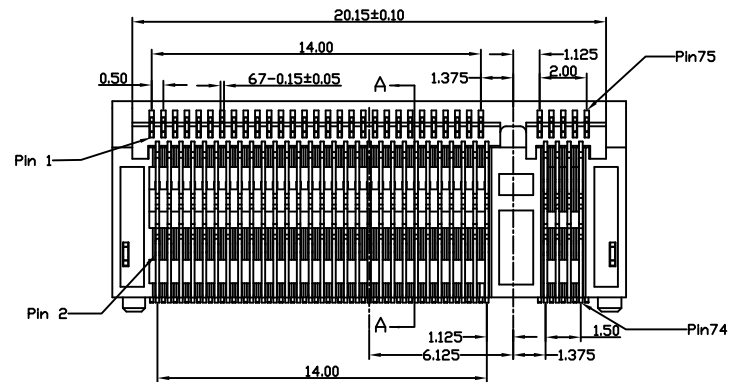

SECTION A-A

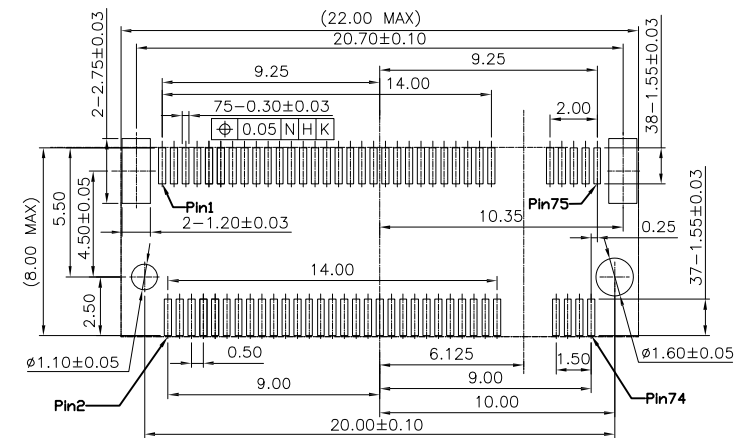

RECOMMENDED PCB LAYOUT(TOP VIEW)
DEFAULT TOLERANCE ±0.05MM

RoHS Compliant

TOLERANCES ARE

MORETHANALL
PCB CONNECTORS
Cable ASSEMBLIES

DRAWING BY CY

X, ±

CHECKED BY GENIUS

.X ± 0.35

UNIT / mm

SCALE 1 : 1

.XX ± 0.20

DATE

.XXX ±

ANG ± 3°

SIZE A4

PJECTION

照片框

ORDER INFORMATION

NGFF-W85R-5809-LF

SERIES | | LEADFREE
58+09 WAY
REEL
HIGH 8.5mm
90°SMT

煜倫股份有限公司

www.morethanall.com

DESCRIPTION: M.2 0.5 Pitch GEN4 H=8.5 67P SMT 臥式(側插) LCP REEL

ITEM	W	A0	B0	K0	K1	P	E	F	D	D1	P0	P2	T
DIM	44.0 ^{+0.3} _{-0.3}	7.75 ^{+0.1} _{-0.1}	22.10 ^{+0.1} _{-0.1}	9.90 ^{+0.1} _{-0.1}	0 ^{+0.1} _{-0.1}	16.00 ^{+0.1} _{-0.1}	1.75 ^{+0.1} _{-0.1}	20.20 ^{+0.1} _{-0.1}	1.5 ^{+0.1} _{-0.0}		4.0 ^{+0.1} _{-0.1}	2.0 ^{+0.1} _{-0.1}	0.5 ^{+0.05} _{-0.05}

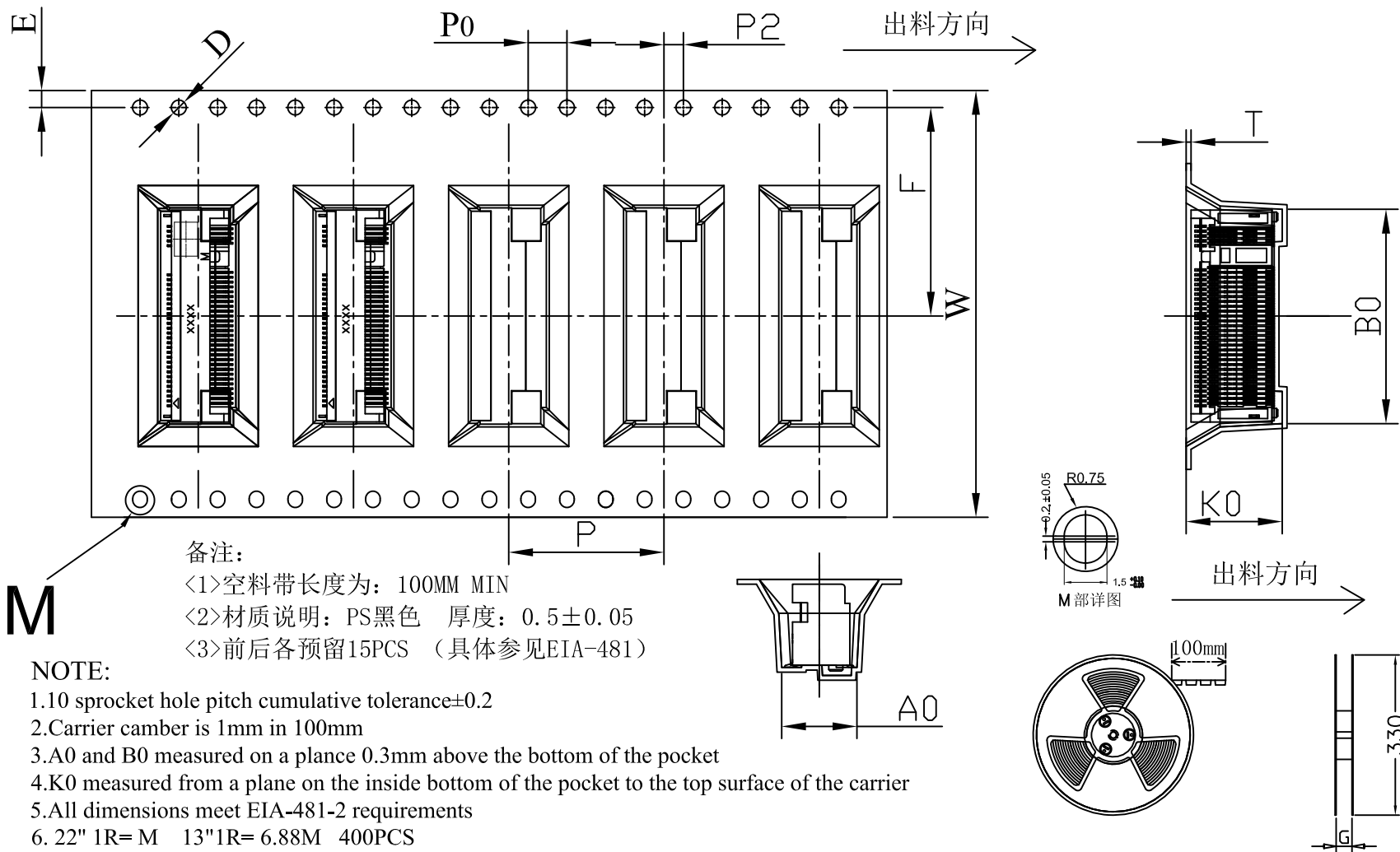

备注:
 <1>空料带长度为: 100MM MIN
 <2>材质说明: PS黑色 厚度: 0.5±0.05
 <3>前后各预留15PCS (具体参见EIA-481)

NOTE:

- 1.10 sprocket hole pitch cumulative tolerance±0.2
- 2.Carrier camber is 1mm in 100mm
- 3.A0 and B0 measured on a plane 0.3mm above the bottom of the pocket
- 4.K0 measured from a plane on the inside bottom of the pocket to the top surface of the carrier
- 5.All dimensions meet EIA-481-2 requirements
6. 22" 1R= M 13" 1R= 6.88M 400PCS
- 7.Carrier part number: 950-06-CR8992

RoHS Compliant

TOLERANCES ARE

MORETHANALL
 PCB CONNECTORS
 Cable ASSEMBLIES

DRAWING BY CY

CHECKED BY GENIUS

UNIT / mm SCALE 1 : 1

DATE

SIZE A4

X, ±
 .X ± 0.35
 .XX ± 0.20
 .XXX ±
 ANG ± 3°

P PROJECTION

照片框

ORDER INFORMATION

NGFF-W85R-5809-LF

SERIES | | LEADFREE
 58+09 WAY
 REEL
 HIGH 8.5mm
 90°SMT

DESCRIPTION: M.2 0.5 Pitch GEN4 H=8.5 67P SMT 卧式(侧插) LCP REEL

煜倫股份有限公司

www.morethanall.com