

Section A-A

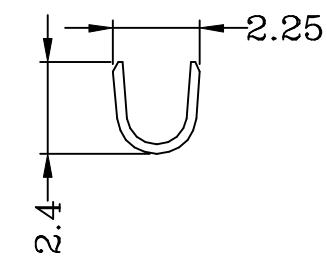

Section B-B

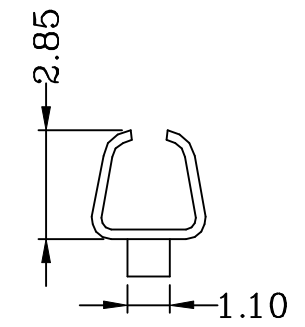

Section C-C

Specifications & Ordering Information:

Part No	Wire Range	Insulation o.d.	Material	Finish	Qty/reel	Note
LV-T-18	AWG #18~#24	2.54mm(max)	Brass	Ni-plated	6,000 PCS	Used for 3 Circuits & Above



煜倫有限公司

PART NO. LV-T-18	
DWG NO. LV-T-18	
FILE NO.	SCALE 1:1
UNIT / mm	

APPROVED BY CY	
DRAWING BY	
PROJECTION	

TOLERANCES ARE
 X
 .XX
 .XXX
 AWG

DESCRIPTION:	10.00-8.00mm pitch crimp terminal			
AREA	REVISIONS	HK	DATE	