

Package Dimensions

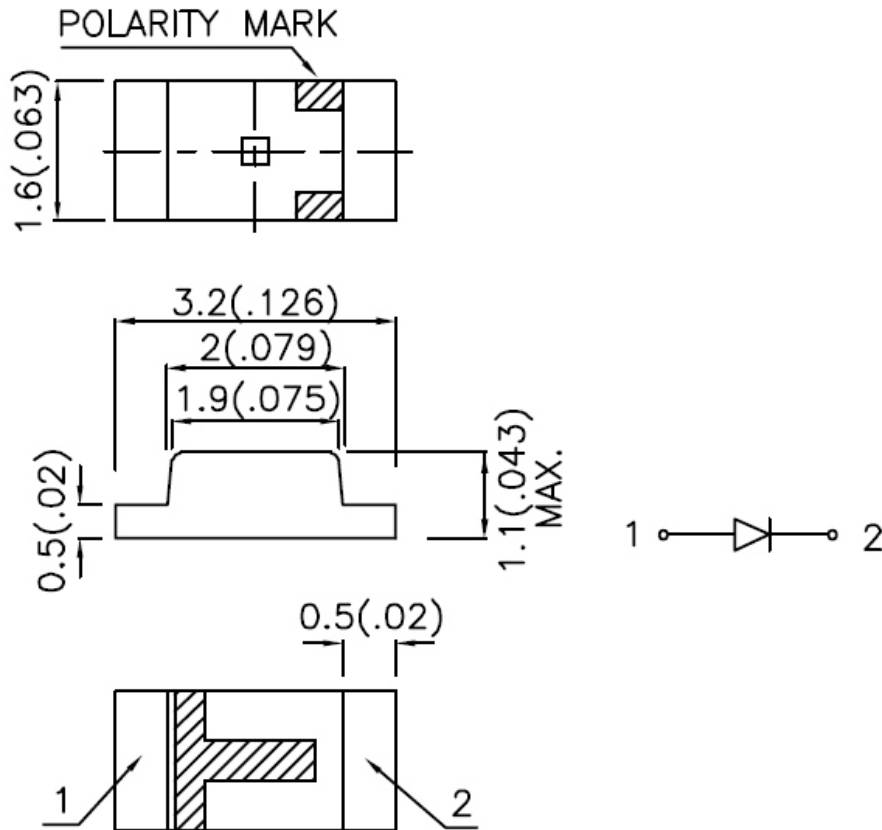

Features

- 3.2mmx1.6mm SMT LED, 1.1mm THICKNESS.
- LOW POWER CONSUMPTION.
- WIDE VIEWING ANGLE.
- IDEAL FOR BACKLIGHT AND INDICATOR.
- VARIOUS COLORS AND LENS TYPES AVAILABLE.
- PACKAGE : 2000PCS / REEL.
- RoHS COMPLIANT.

Description

The Yellow source color devices are made with Gallium Arsenide Phosphide on Gallium Phosphide Yellow Light Emitting Diode.

LED-VYL-11-LF
LEADFREE

RoHS Compliant

MORETHANALL
CONNECTORS
ASSEMBLIES

PART NO. **LED-VYL-11**

DWG NO. **LED-VYL-11**

CHECKED BY CY

TOLERANCES ARE

DESCRIP TION:

FILE NO.

DRAWING BY

.X ± 0.2
.XX ±
.XXX ±
AWG

AREA

REVISIONS

HK

DATE

煜倫股份有限公司

UNIT / mm

SCALE 1:1

PROJECTION

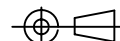

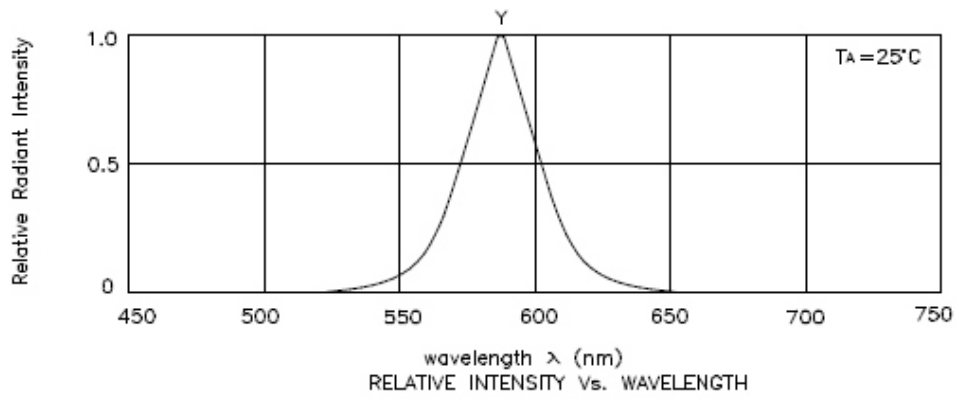

Yellow

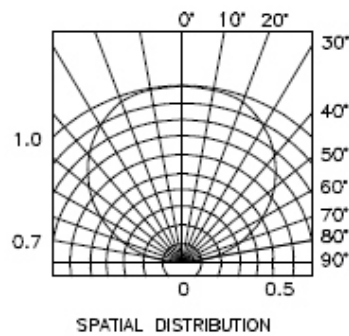
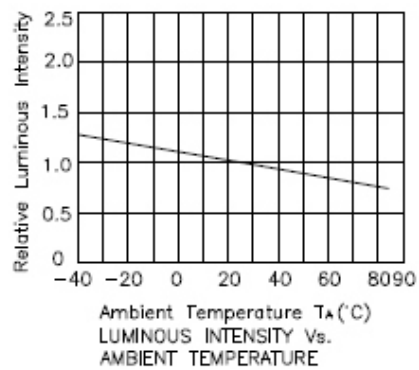
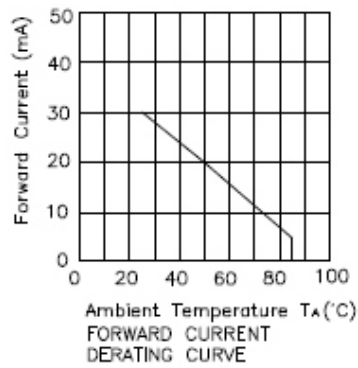
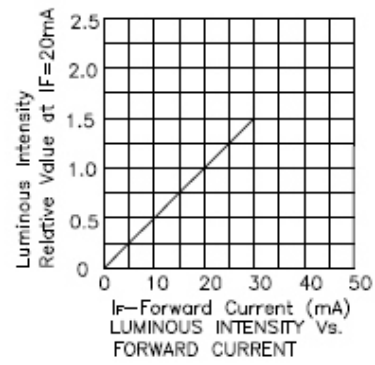
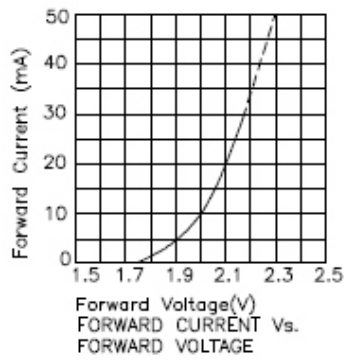

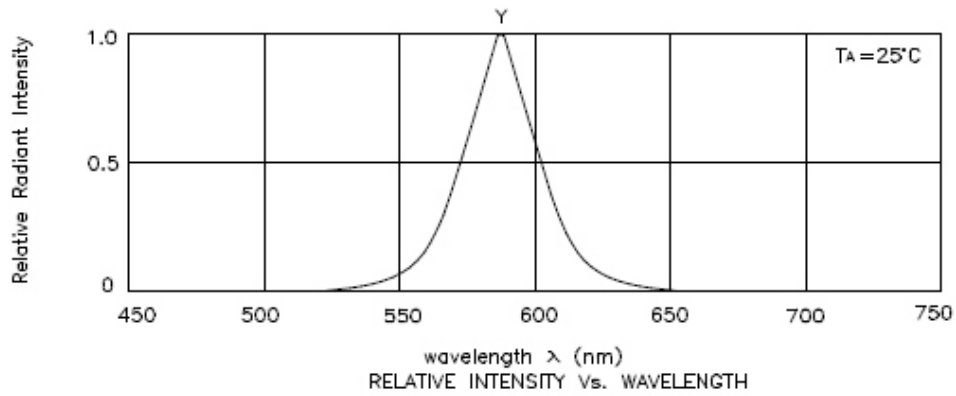

Yellow

KP-3216YW

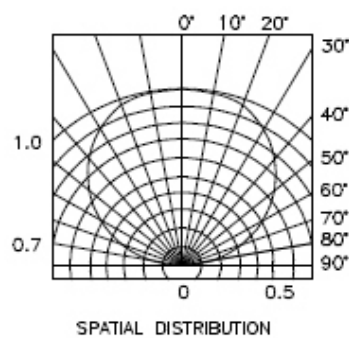
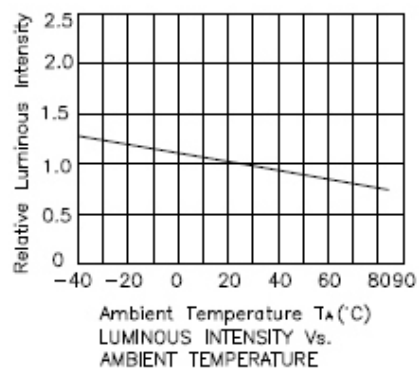
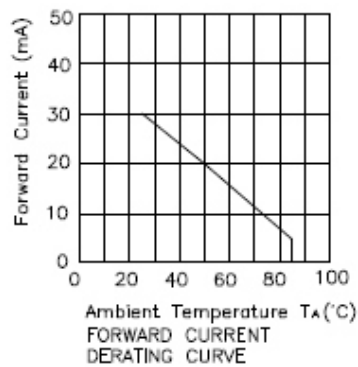
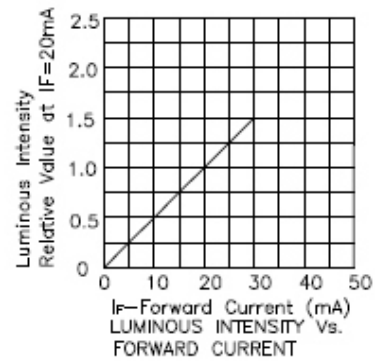
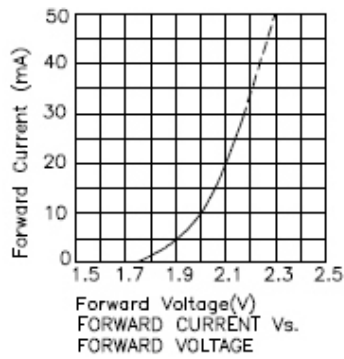

Reflow Soldering Profile For Lead-free SMT Process.

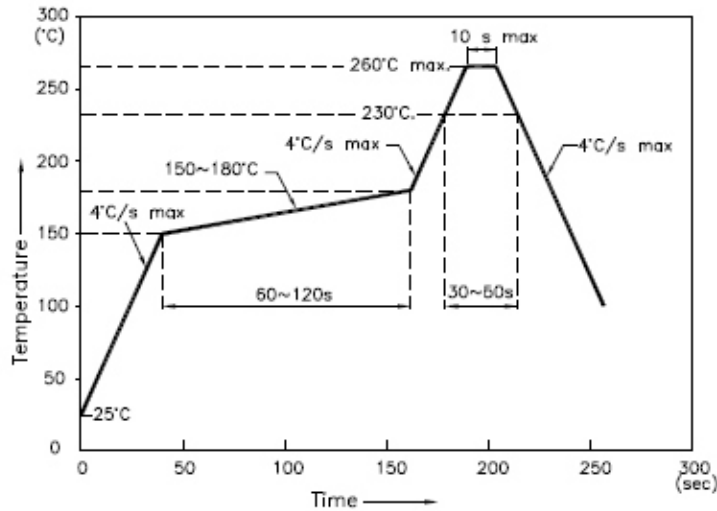

NOTES:

1. We recommend the reflow temperature 245°C(+/-5°C). The maximum soldering temperature should be limited to 260°C.
2. Don't cause stress to the epoxy resin while it is exposed to high temperature.
3. Number of reflow process shall be 2 times or less.

Recommended Soldering Pattern
(Units : mm)

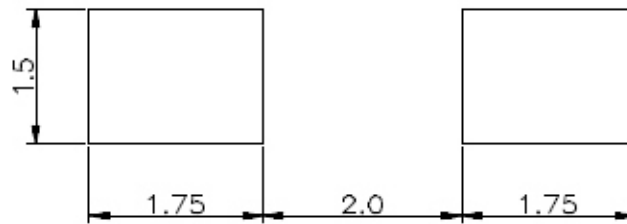

Tape Specifications
(Units : mm)

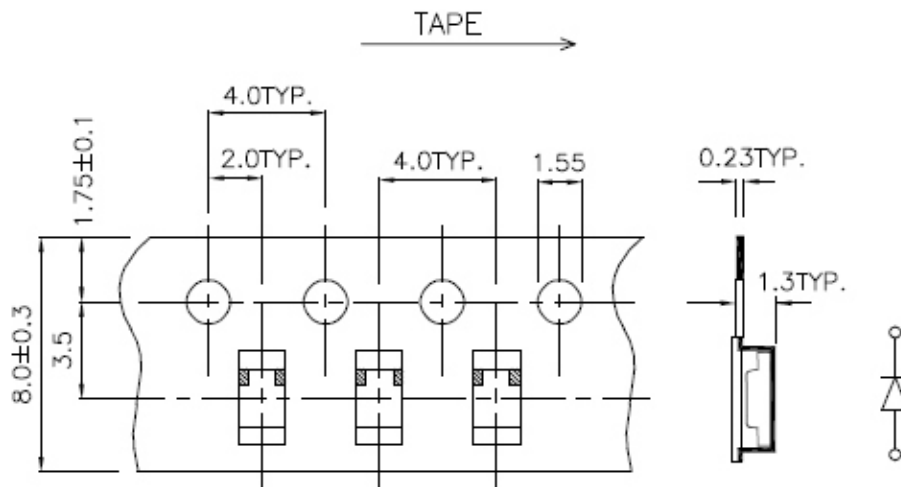

Remarks:

If special sorting is required (e.g. binning based on forward voltage, luminous intensity or wavelength), the typical accuracy of the sorting process is as follows:

1. Wavelength: +/-1nm
2. Luminous Intensity: +/-15%
3. Forward Voltage: +/-0.1V

Note: Accuracy may depend on the sorting parameters.