

RoHS Compliant

TOLERANCES ARE

MORETHANALL
PCB CONNECTORS
Cable ASSEMBLIES

DRAWING BY CY

X, ±

CHECKED BY GENIUS

.X ± 0.38

UNIT / mm

SCALE 1 : 1

.XX ± 0.25

DATE

.XXX ±

ANG ±

照片框

ORDER INFORMATION

HDMI-SVM3PEC-19-LF

SERIES

LEADFREE

19WAY

MYLAR

PANEL EAR

METAL FOOT x 3

FEMALE

180°SMT

煜倫股份有限公司

www.morethanall.com

SIZE A4

PJECTION

DESCRIPTION: HDMI RECEPTACLE WITH WING VERTICAL SMT TYPE

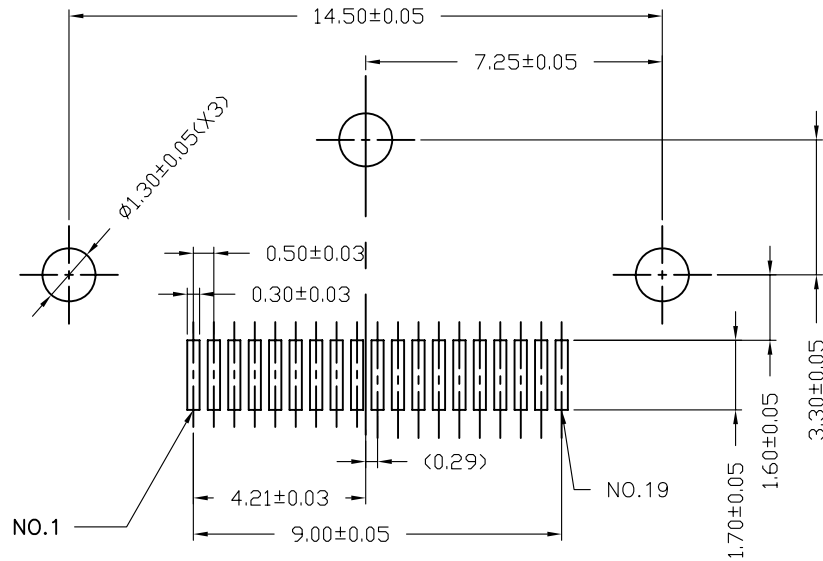

RECOMMENED P.C.B. LAYOUT(T=1.6mm)

REMARKS:

1. MATERIAL:
 - 1.1 INSULATOR: THERMOPLASTIC UL 94V-0 RATED
 - 1.2 CONTACT: COPPER ALLOY
 - 1.3 SHELL: COPPER ALLOY
2. PLATING:
 - 2.1 CONTACT: GOLD PLATED OVER NICKEL ON CONTACT AREA AND 100u" MIN. TIN PLATED OVER NICKEL ON SOLDER TAILS
 - 2.2 SHELL: SOLDERABLE NICKEL PLATED OVER NICKEL
3. THIS PART SHOULD CONTAIN ANY SUBSTANCES WHICH ARE SPECIFIED IN KOA-2V03
4. CONTACT RETAIN FORCE: 0.3KG MIN

1	POLYIMIDE :7X12(mm)	HONGHUI	FILM	6
1	THERMOPLASTIC	KINGFA	DIRTYPROOF	5
10	COPPER ALLOY,T=0.25mm	TONGXIANG	SHORT CONTACT	4
9	COPPER ALLOY,T=0.25mm	TONGXIANG	LONG CONTACT	3
1	COPPER ALLOY,T=0.50mm	TONGXIANG	SHELL	2
1	THERMOPLASTIC	KINGFA	INSULATOR	1
QTY'S	SPECIFICATION	SUPPLIER	PART	ITEM

RoHS Compliant

TOLERANCES ARE

MORETHANALL
PCB CONNECTORS
Cable ASSEMBLIES

煜倫股份有限公司

www.morethanall.com

DRAWING BY CY

CHECKED BY GENIUS

UNIT / mm

SCALE 1 : 1

DATE

SIZE A4

X, ±
.X ± 0.38
.XX ± 0.25
.XXX ±
ANG ±

PPOJECTION

照片框

ORDER INFORMATION

HDMI-SVM3PEC-19-LF
SERIES | | | | | LEADFREE
19WAY
MYLAR
PANEL EAR
METAL FOOT x 3
FEMALE 180°SMT

DESCRIPTION: HDMI RECEPTACLE WITH WING VERTICAL SMT TYPE