

SPECIFICATIONS

ELECTRICAL CHARACTERISTICS:

Contact Current Rating: 3 Amperes.(Max)
 Dielectric Withstanding Voltage: AC 1000V/60sec. r.m.s.
 Insulation Resistance: 500 Megohms Minimum.
 Contact Resistance: 20 Milliohms Maximum.
 Operating Temperature: -55°C to +105°C.

MECHANICAL CHARACTERISTICS:

Contact Insertion Force: 341 g. Maximum.
 Contact Separation Force: 21 g. Minimum.
 Grounding Screw Torque: 3 Kg Minimum.

MATERIALS:

Contacts: Brass.
 Insulator: PBT UL 94V-0 Rated.
 Shell: Cold Roller Steel.
 Grounding Screw: Brass.

FINISHES:

Contact: Gold Flash.
 Shell: Nickel Plated.
 Grounding Screw: Tin/Lead Plated Over Nickel Underplating.

DY-S-25-LF
 LEADFREE
 RoHS Compliant

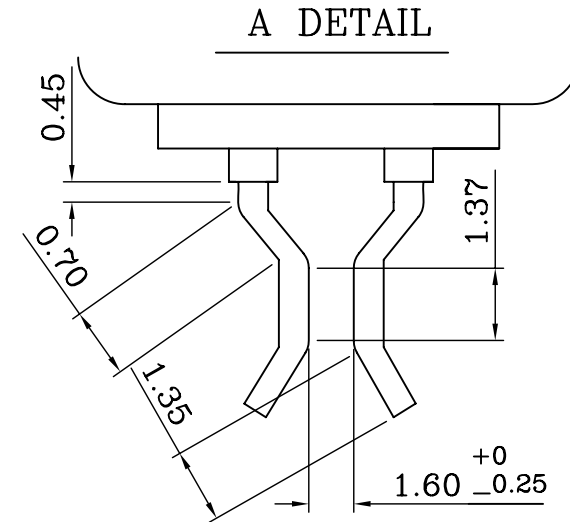
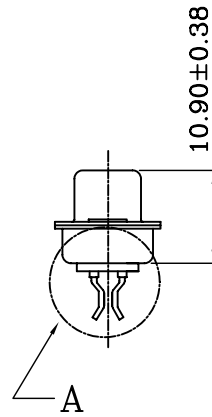
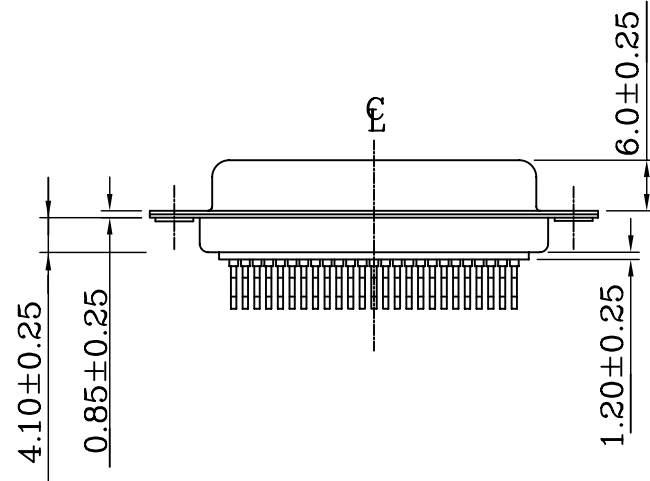
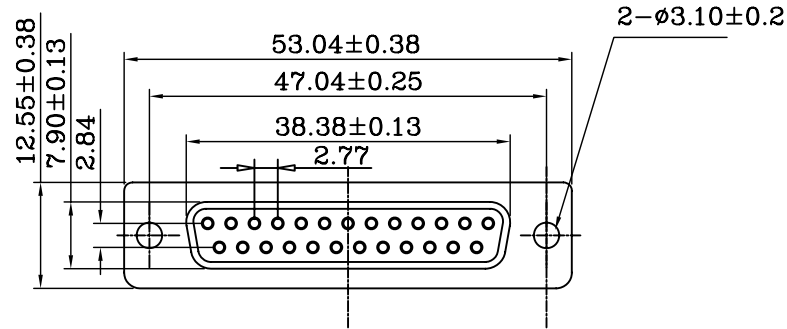

MORETHANALL
 CONNECTORS
 ASSEMBLIES

PART NO. DY-S-25

DWG NO. DY-S-25

CHECKED BY CY

TOLERANCES ARE

DESCRIPTION: **CLIP S.M.T TYPE**

FILE NO.

DRAWING BY

.X ± 0.25
 .XX ± 0.13
 .XXX ±
 AWG

AREA REVISIONS HK DATE

焜倫股份有限公司

UNIT / mm

SCALE 1:1

PROJECTION

AREA REVISIONS HK DATE