

SPECIFICATIONS

ELECTRICAL CHARACTERISTICS:

Contact Current Rating: 3 Amperes.(Max)
 Dielectric Withstanding Voltage: AC 1000V/60sec. r.m.s.
 Insulation Resistance: 500 Megohms Minimum.
 Contact Resistance: 20 Milliohms Maximum.
 Operating Temperature: -55°C to +105°C.

MECHANICAL CHARACTERISTICS:

Contact Insertion Force: 341 g. Maximum.
 Contact Separation Force: 21 g. Minimum.
 Grounding Screw Torque: 3 Kg Minimum.

MATERIALS:

Contacts: Brass.
 Insulator: PBT UL 94V-0 Rated.
 Shell: Cold Roller Steel.
 Grounding Screw: Brass.

FINISHES:

Contact: Gold Flash.
 Shell: Nickel Plated.
 Grounding Screw: Tin/Lead Plated Over Nickel Underplating.

DY-P-25-LF

LEADFREE

RoHS Compliant

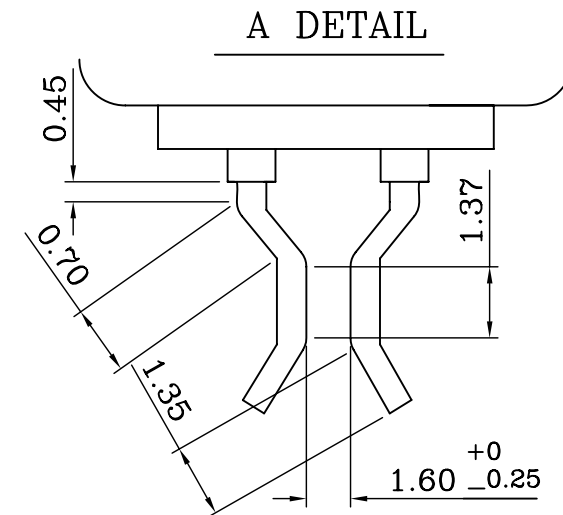
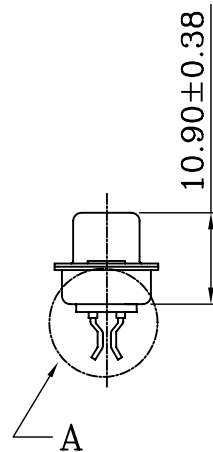
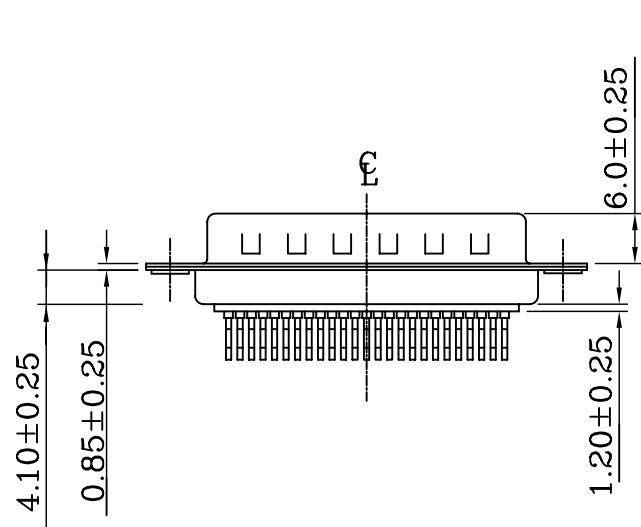

MORETHANALL
CONNECTORS
ASSEMBLIES

PART NO. DY-P-25

DWG NO. DY-P-25

FILE NO.

CHECKED BY CY

DRAWING BY

TOLERANCES ARE

.X ± 0.25
.XX ± 0.13
.XXX ±
AWG

DESCRIPTION:

**2.77 mm D-SUB PLUG
CLIP S.M.T TYPE**

焜倫股份有限公司

UNIT / mm

SCALE 1:1

PROJECTION

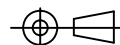

AREA

REVISIONS

HK

DATE