

1 2 3 4 5 6 7 8 9 0

J
I
H
G
F
E
D
C
B
A

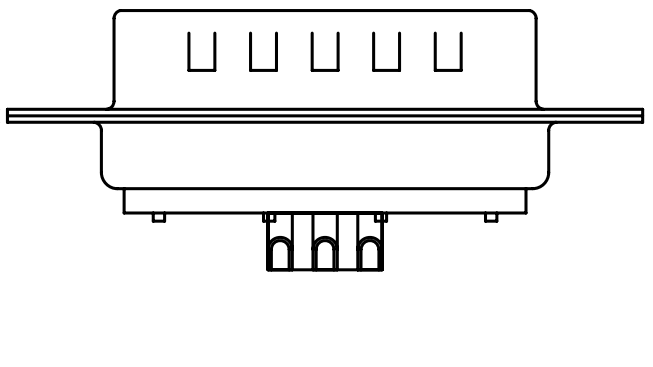
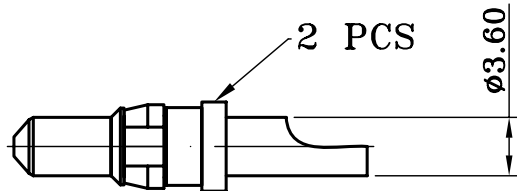
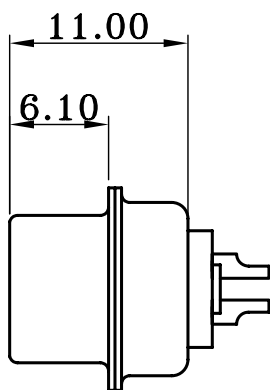
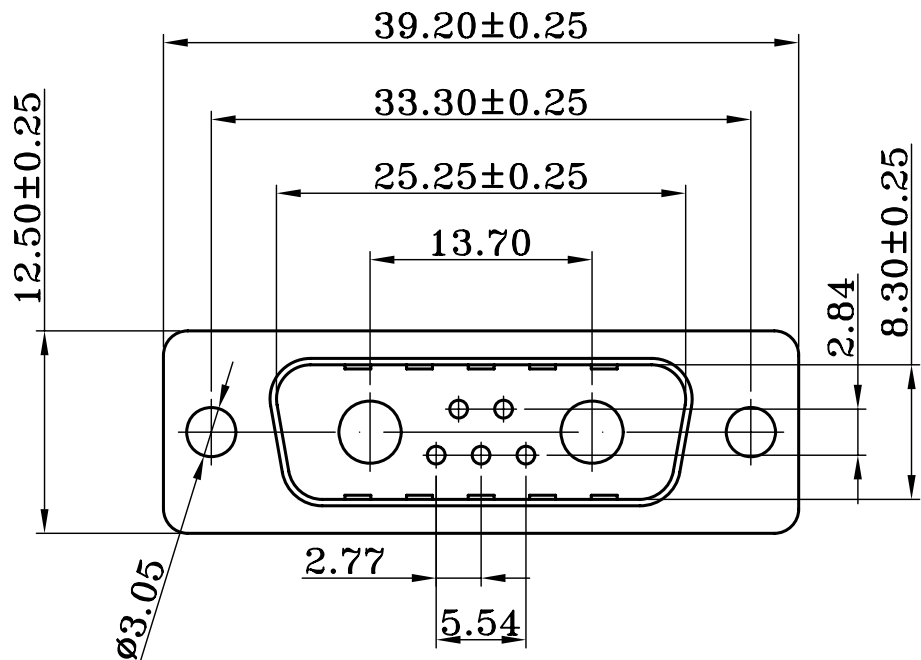

MATERIALS AND FINISH
 SHELL : STEEL MATERIAL, FRONT SHELL TIN FINISHED
 BACK SHELL TIN FINISHED
 DIMPLES ON PLUG ONLY
 INSULATOR : PBT THERMOPLASTIC, 30% GLASS FILLED,
 UL 94V-0 RATED, BLACK COLOR
 SIGNAL CONTACT MATERIAL: COPPER ALLOY, FULL GOLD FLASH
 HIGH POWER CONTACT MATERIAL: COPPER ALLOY
 15u" GOLD PLATED

ELECTRICAL CHARACTERISTICS
 HIGH POWER CONTACT CURRENT RATING : 20 AMPS
 HIGH POWER CONTACT RESISTANCE : 2.7 MILLIOHMS MAX.
 DIELECTRIC WITHSTANDING VOLTAGE : 1000 V AC FOR 1 MINUTE
 INSULATION RESISTANCE : 5000 MEGAOHMS

DWS-P20G15-07W2-LF
 LEADFREE

RoHS Compliant



PART NO. DWS-P20G15-07W2

DWG NO. DWS-P20G15-07W2

CHECKED BY CY

TOLERANCES ARE

DESCRIP TION:

FILE NO.

DRAWING BY

.X ± 0.2
.XX ± 0.1
.XXX ±
AWG

AREA REVISIONS HK DATE

煜倫股份有限公司

UNIT / mm

SCALE 1:1

PROJECTION

AREA REVISIONS HK DATE