

1 2 3 4 5 6 7 8 9 0

J
I
H
G
F
E
D
C
B
A

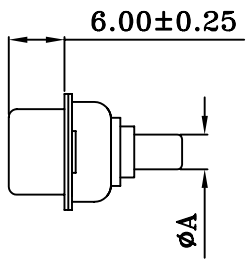

PART NO.	Current Rating	Dimension	Dimension
		Ø A	ØB
DWD-P40-09W4	40 AMPS	Ø3.75	Ø4.20
DWD-P20-09W4	20 AMPS	Ø2.8	Ø3.28
DWD-P10-09W4	10 AMPS	Ø1.7	Ø2.20

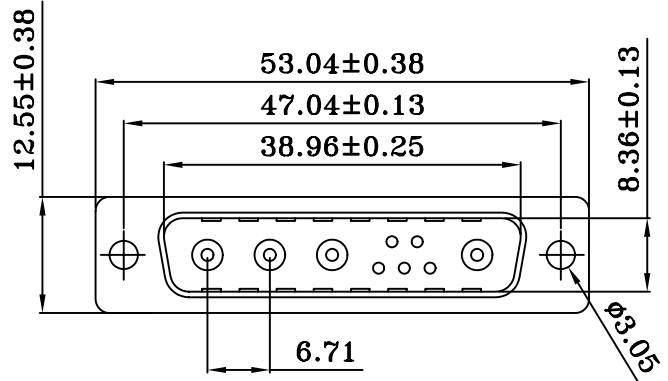
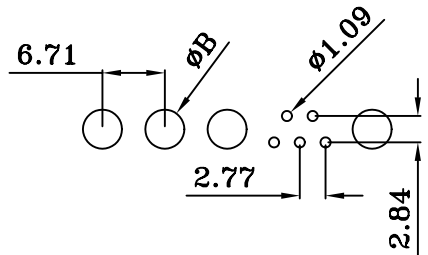
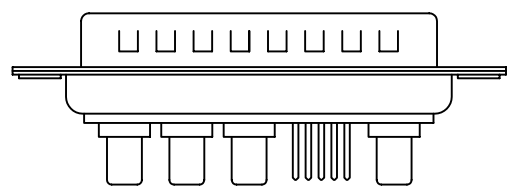

PCB LAYOUT

MATERIALS AND FINISH

SHELL : STEEL MATERIAL, TIN FINISHED
 DIMPLES ON PLUG ONLY
 CONNECTOR INSULATOR : PBT THERMOPLASTIC,
 30% GLASS FILLED, UL 94V-0 RATED, BLACK COLOR
 SIGNAL CONTACT MATERIAL: BRASS, FULL GOLD FLASH
 HIGH POWER CONTACT MATERIAL: BRASS, 15u" GOLD PLATED

ELECTRICAL CHARACTERISTICS

HIGH POWER CONTACT CURRENT RATING :10,20,OR 40 AMPS
 HIGH POWER CONTACT RESISTANCE : 2.7 MILLIOHMS MAX.
 DIELECTRIC WITHSTANDING VOLTAGE :
 1000 V AC FOR 1 MINUTE
 INSULATION RESISTANCE : 5000 MEGAOHMS MIN.
 TEMPERATURE RATING : -55°C ~ +125°C



煜倫有限公司

PART NO. DWD-Pxx-09W4		CHECKED BY CY		TOLERANCES ARE .X .XX .XXX AWG	DESCRIP TION: D-SUB CONNECTOR (Power Contact Straight DIP Type)	AREA	REVISIONS	HK	DATE
DWG NO. DWD-Pxx-09W4		DRAWING BY							
FILE NO.		PROJECTION							
UNIT / mm	SCALE 1:1								