

SPECIFICATION
MATERIAL
 Insulator: Thermal Plastic UL94V-0
 Contacts: Copper Alloy
 Shell: Steel
 Rivet, Boardlock: Copper Alloy
CONTACT PLATING
 Underplate: 50u" Nickel
 Contact Area: 1u"~30u" Selective Gold
 Solder Tails Area: 100u" Tin/Lead(Brighten Tin) or
 100u" Tin/Lead Free(Brighten Tin/Matte Tin)
ELECTRICAL
 Operation Voltage: 250 VAC Max.
 Current Rating: 3 Amps Max.
 Contact Resistance: 15 mohms Max.
 Insulation Resistance: 3000 Mohms Min @ 500 VDC
 Dielectric Withstanding Voltage: 1000 VAC / Minute
 Operating Temperature: -55°C To +105°C

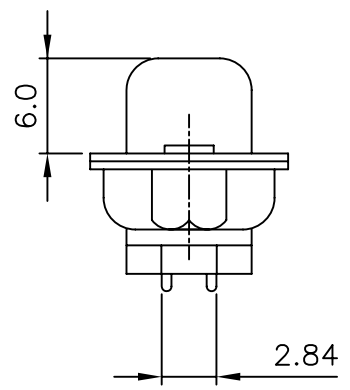
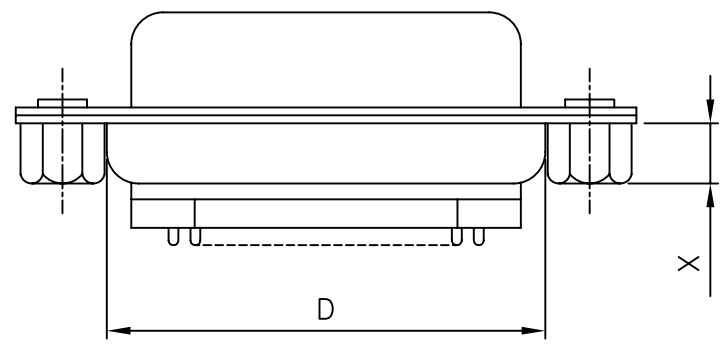

POSITION	A	B	C	D
9F	16.30	25.00	30.8	19.2
15F	24.60	33.30	39.2	27.7
25F	38.30	47.10	53.1	41.1
37F	54.80	63.50	69.4	57.3

DSF-SGN-xx-LF
 LEADFREE

RoHS Compliant

MORETHANALL
 CONNECTORS
 ASSEMBLIES

焯倫股份有限公司

PART NO. DSF-SGN-xx		CHECKED BY CY		TOLERANCES ARE .X ± 0.3 .XX ± 0.2 .XXX ± AWG	DESCRIP TION: D-SUB SOLDER WITH E.M.I FILTER		
DWG NO. DSF-SGN-xx		DRAWING BY					
UNIT / mm	SCALE 1:1	PROJECTION		AREA	REVISIONS	HK	DATE