

SPECIFICATIONS

ELECTRICAL CHARACTERISTICS:

Contact Current Rating: 5 Amperes.
 Dielectric Withstanding Voltage: AC 1000/60sec.r.m.s.
 Insulation Resistance: 5000 Medohms Minimum
 Contact Resistance: 25 Milliohms Maximum.
 Operating Temperature: -55°C to +105°C.

MECHANICAL CHARACTERISTICS:

Contact Insertion Force: 341 g. Maximum.
 Contact Separation Force: 21 g. Minimum.

MATERIALS:

Contacts: Brass.
 Insulator: PBT UL 94V-0 Rated.
 Shell: Cold Roller Steel.

FINISHES:

Contact: Gold Flash.
 Shell: Nickel Plated.

DRB1-FN19J-2525-LF

LEADFREE

RoHS Compliant

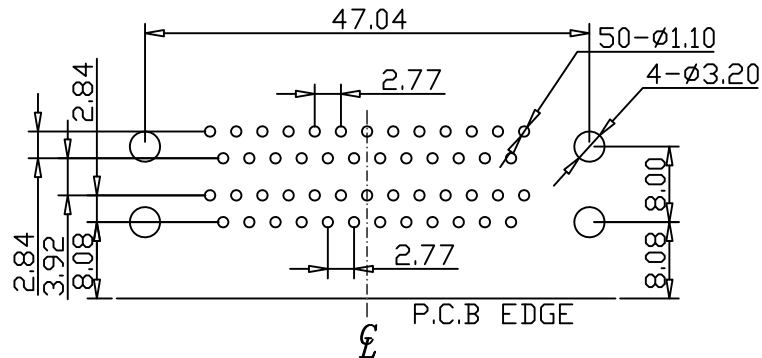

RECOMMENDED P.C.B LAYOUT

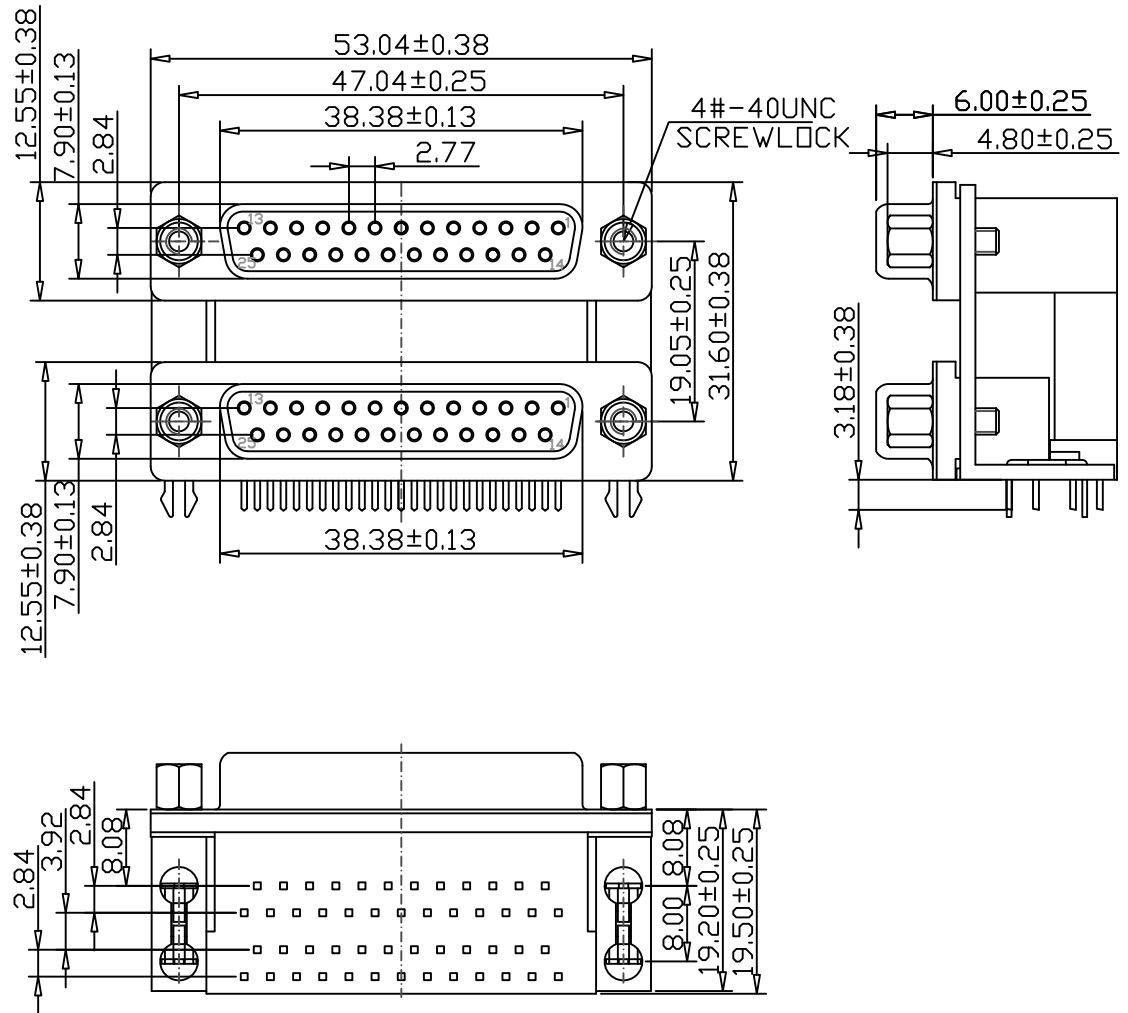

MORETHANALL
 CONNECTORS
 ASSEMBLIES

PART NO. DRB1-FN19J-2525

DWG NO. DRB1-FN19J-2525

FILE NO.

UNIT / mm

SCALE 1:1

CHECKED BY CY

DRAWING BY

PROJECTION

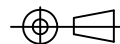

TOLERANCES ARE

.X ± 0.35
 .XX ± 0.25
 .XXX ± 0.13
 AWG

DESCRIPTION:

**D-SUB CONNECTOR 25 FEMALE/25 FEMALE
 DUAL PORT**

AREA

REVISIONS

HK

DATE

焯倫股份有限公司