

NOTES:

1. INSULATOR: GLASS FILLED NYLON 9T, UL94V-0
2. CONTACT: COPPER ALLOY
3. CONTACT FINISH: 1. GOLD FLASH ON CONTACT AREA
TIN/LEAD ON SOLDER AREA, BOTH OVER NICKEL
2. GOLD FLASH ON CONTACT OVER NICKEL (LEADFREE)
4. SHELL: 0. COPPER ALLOY, GOLD FLASH ON SOLDER AREA OVER NICKEL
1. NI-AG ALLOY
5. PACKING TYPE: SPACE: TUBE
. REEL R

DIMENSIONS

30	DF19-WXF10R-30	29.00	33.55	36.75	34.15
20	DF19-WXF10R-20	19.00	23.55	26.75	24.15
14	DF19-WXF10R-14	13.00	17.55	20.75	18.15
08	DF19-WXF10R-08	7.00	11.55	14.75	12.15
CKT.	PART NO.	A	B	C	D

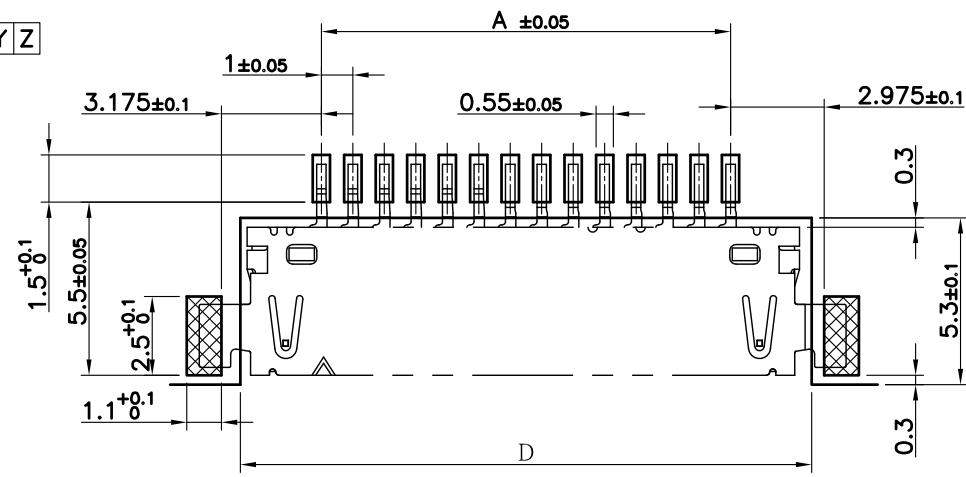

RECOMMENDED PCB LAYOUT(TOP VIEW)

RoHS Compliant

TOLERANCES ARE

MORETHANALL
PCB CONNECTORS
Cable ASSEMBLIES

DRAWING BY CY

X.±

CHECKED BY GENIUS

.X±

UNIT / mm

SCALE 1 : 1

.XX±

DATE

.XXX±

ANG ±

SIZE A4

PJECTION

照片框

ORDER INFORMATION

DF19-WXF10R-xx-LF
SERIES | | | LEADFREE
| | | 08~30WAY
| | | REEL
| | | OFFSET 1.1mm
| | | NON POST
| | | 90°SMT

DESCRIPTION: Right Angle Pin Header SMT (Offset Type 1.0mm)

煜倫股份有限公司

www.morethanall.com

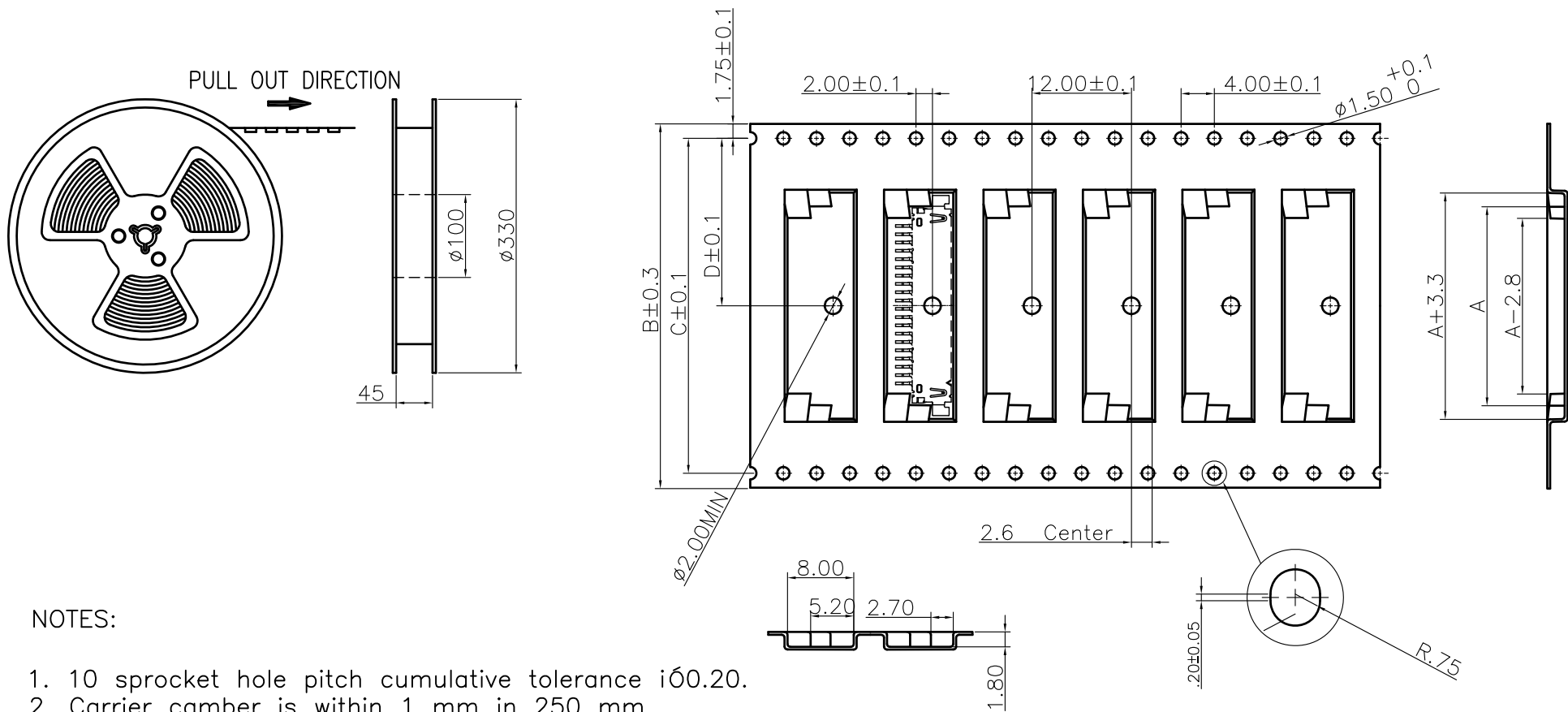

NOTES:

1. 10 sprocket hole pitch cumulative tolerance ± 0.20 .
2. Carrier camber is within 1 mm in 250 mm.
3. Material :Black Conductive Polystyrene Alloy (UP-6100).
4. All dimensions meet EIA-481-B requirements.
5. Thickness: 0.35 ± 0.05 mm.
6. Component load per 13" reel: 2500pcs.

20	24.0	44.0	40.4	20.2
30	34.0	56.0	52.4	26.2
CKT	A	B	C	D

RoHS Compliant

TOLERANCES ARE

MORETHANALL
PCB CONNECTORS
Cable ASSEMBLIES

DRAWING BY CY

X. ±

CHECKED BY GENIUS

.X ±

UNIT / mm

SCALE 1 : 1

.XX ±

DATE

.XXX ±

ANG ±

照片框

ORDER INFORMATION

DF19-WXF10R-xx-LF

SERIES | | | | LEADFREE
| | | | 08-30WAY
| | | | REEL
| | | | OFFSET 1.1mm
| | | | NON POST
| | | | 90°SMT

煜倫股份有限公司

www.morethanall.com

SIZE A4

PJECTION

DESCRIPTION: Right Angle Pin Header SMT (Offset Type 1.0mm)

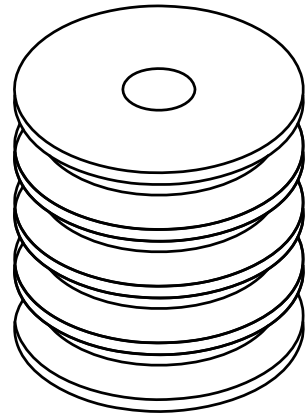

6RE/BC & 5RE/BC

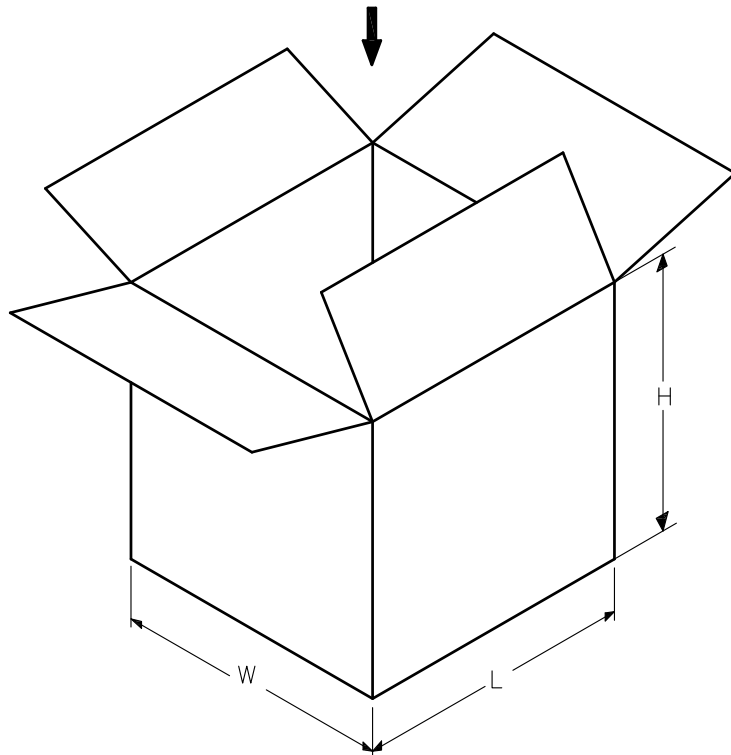

PACKING MATERIAL

PART NAME	DIM(mm)
REEL	ø300*(B+1)
BIG CRTON	350X350X340

PACKING CAPACITY

PART NO.	PCS/RE	RE/BC	PCS/BC
DF19-WXF10R-20	2500PCS/RE	6 RE/BC	15K PCS/BC
DF19-WXF10R-30	2500PCS/P	5 RE/BC	12.5K PCS/BC

RoHS Compliant

TOLERANCES ARE

MORETHANALL
PCB CONNECTORS
Cable ASSEMBLIES

煜倫股份有限公司

www.morethanall.com

DRAWING BY CY

CHECKED BY GENIUS

UNIT / mm SCALE 1 : 1

DATE

SIZE A4

X. ±
.X ±
.XX ±
.XXX ±
ANG ±

PPOJECTION

照片框

ORDER INFORMATION

DF19-WXF10R-xx-LF
SERIES | | | | LEADFREE
| | | | 08~30WAY
| | | | REEL
| | | | OFFSET 1.1mm
| | | | NON POST
| | | | 90°SMT

DESCRIPTION: Right Angle Pin Header SMT (Offset Type 1.0mm)