

21P~30P  
SCALE 0.8:1

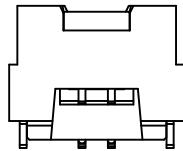

02P

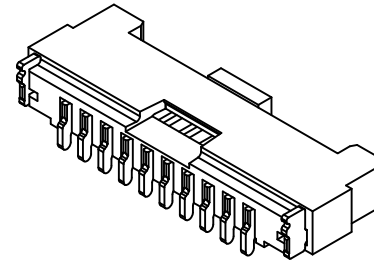

**SPECIFICATIONS**

Current Rating: 1A AC,DC  
 Voltage Rating: 150V AC,DC  
 Temperature Range: -25°C ~ +85°C  
 Contact Resistance: 20mΩ Max.  
 Insulation Resistance: 500MΩ Min.  
 Withstanding Voltage: 500V AC/minute  
 Pin Material: Brass/Gold-flash  
 Nickel-plated 30u" ↑  
 Solder Tabs: Brass/Gold-flash  
 Nickel-plated 30u" ↑  
 Material: LCP/Nylon 6T,UL94V-0  
 Color: Natural(Black)

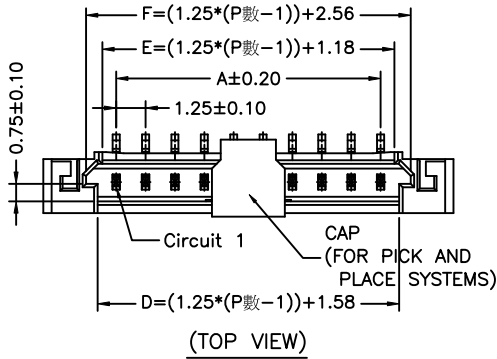

(TOP VIEW)

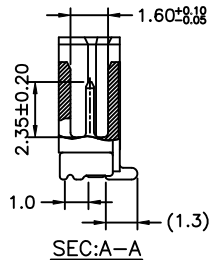
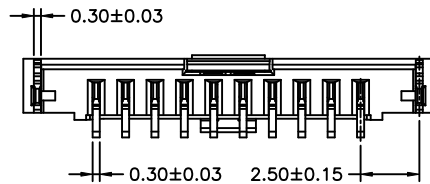
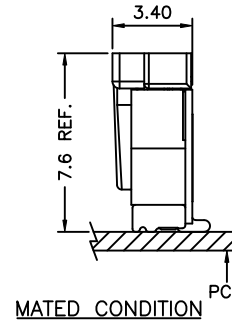
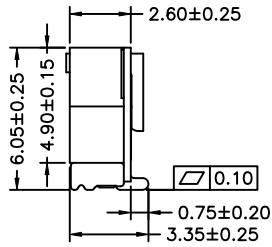
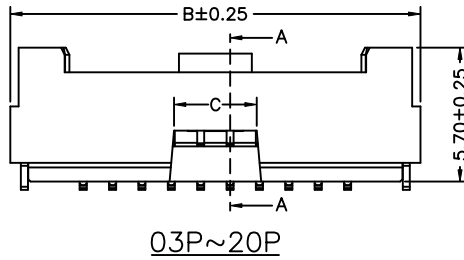
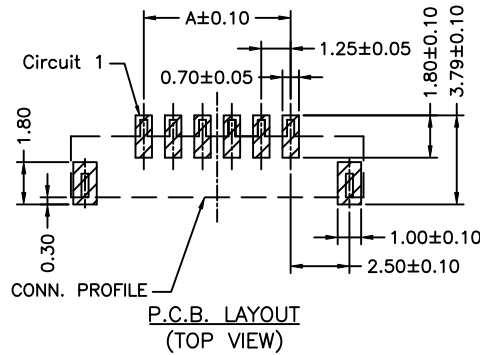

Circuit No.	Dimensions		
	A	B	C
02P	1.25	7.45	3.50
03P	2.50	8.70	3.50
04P	3.75	9.95	3.50
05P	5.00	11.20	3.50
06P	6.25	12.45	3.50
07P	7.50	13.70	3.50
08P	8.75	14.95	3.50
09P	10.00	16.20	3.50
10P	11.25	17.45	3.50
11P	12.50	18.70	5.00
12P	13.75	19.95	5.00
13P	15.00	21.20	5.00
14P	16.25	22.45	5.00
15P	17.50	23.70	5.00
20P	23.75	29.95	5.00
25P	30.00	36.20	6.00
30P	36.25	42.45	6.00

**RoHS Compliant**

TOLERANCES ARE

**MORETHANALL**  
 PCB CONNECTORS  
 Cable ASSEMBLIES

DRAWING BY CY  
 CHECKED BY GENIUS  
 UNIT / mm SCALE 1 : 1  
 DATE

X, ±  
 .X ± 0.25  
 .XX ± 0.15  
 .XXX ± 0.05  
 ANG ±

照片框

**ORDER INFORMATION**

DF14L-VXCR-xx-LF  
 SERIES REEL CAP NON POST 180°SMT  
 LEADFREE 02-30WAY

**煜倫股份有限公司**

www.morethanall.com

SIZE A4 PROJECTION

DESCRIPTION: 1.25mm PITCH 180° WAFER-SMT TYPE, ULTRA LOW PROFILE, WITHOUT BOSS

02~07 Contacts

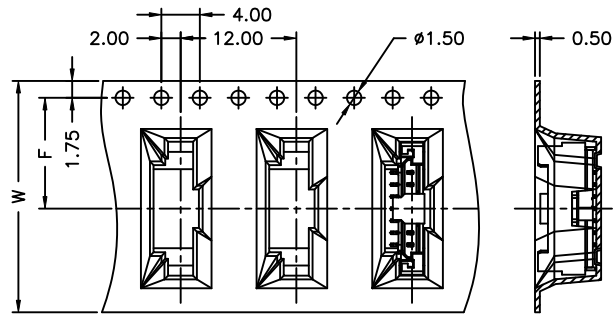

Unreeling direction →

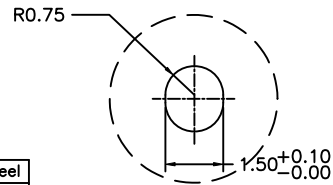
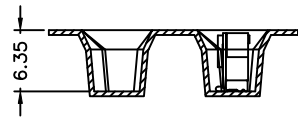

SCALE 4:1  
DETAIL A

08~30 Contacts

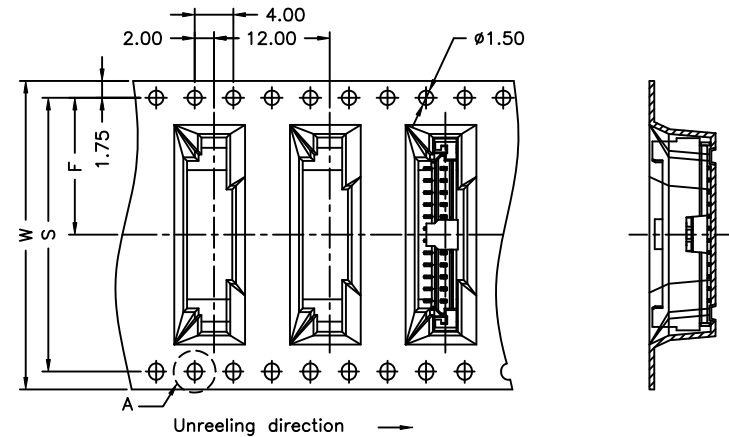

Unreeling direction →

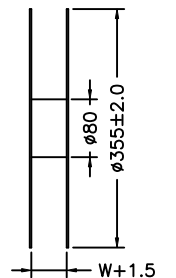
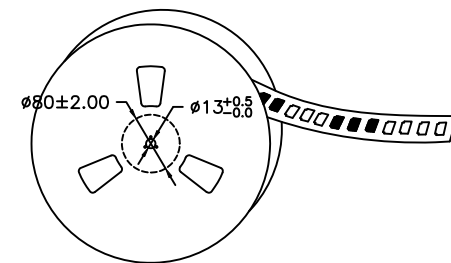
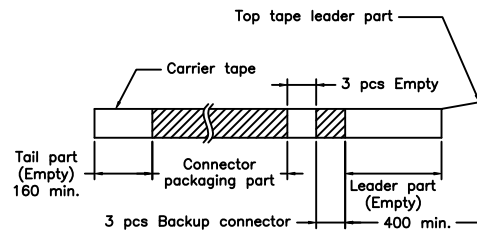

Number of Contacts	W±0.3	F±0.1	S±0.1	Q'ty/Reel
02P	24	11.50		1,000
03P	24	11.50		1,000
04P	24	11.50		1,000
05P	24	11.50		1,000
06P	24	11.50		1,000
07P	24	11.50		1,000
08P	32	14.20	28.40	1,000
09P	32	14.20	28.40	1,000
10P	32	14.20	28.40	1,000
11P	32	14.20	28.40	1,000
12P	44	20.20	40.40	1,000
13P	44	20.20	40.40	1,000
14P	44	20.20	40.40	1,000
15P	44	20.20	40.40	1,000
20P	44	20.20	40.40	1,000
25P	56	26.20	52.40	1,000
30P	56	26.20	52.40	1,000

NOTE:  
Material: Transparent  
Anti-static Polystyrene.

RoHS Compliant

TOLERANCES ARE

**MORETHANALL**  
PCB CONNECTORS  
Cable ASSEMBLIES

DRAWING BY CY

CHECKED BY GENIUS

UNIT / mm

SCALE 1:1

DATE

SIZE A4

PJECTION

X, ±  
.X ± 0.25  
.XX ± 0.15  
.XXX ± 0.05  
ANG ±

照片框

ORDER INFORMATION

DF14L-VXCR-xx-LF

SERIES LEADFREE  
02-30WAY  
REEL  
CAP  
NON POST  
180°SMT

DESCRIPTION: 1.25mm PITCH 180° WAFER-SMT TYPE, ULTRA LOW PROFILE, WITHOUT BOSS

煜倫股份有限公司

www.morethanall.com