

SPECIFICATIONS

ELECTRICAL CHARACTERISTICS:

Contact Current Rating: 3 Amperes.
 Dielectric Withstanding Voltage: AC 1000/60sec.r.m.s.
 Insulation Resistance: 5000 Medohms Minimum.at DC 500V.
 Contact Resistance: 25 Milliohms Maximum.
 Operating Temperature: -55°C to +105°C.

MECHANICAL CHARACTERISTICS:

Contact Insertion Force: 341 g. Maximum.
 Contact Separation Force: 21 g. Minimum.

MATERIALS:

Contacts: Brass.
 Insulator: PBT UL 94V-0 Rated.
 Shell: Cold Roller Steel.

FINISHES:

Contact: Gold Flash.
 Shell: Nickel Plated.

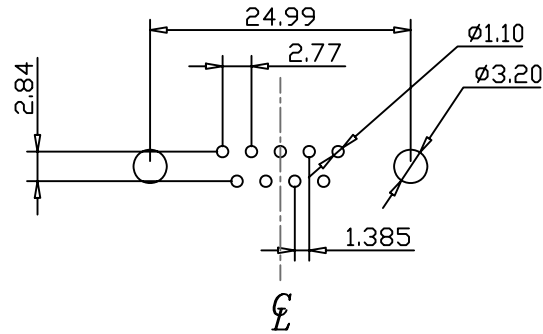
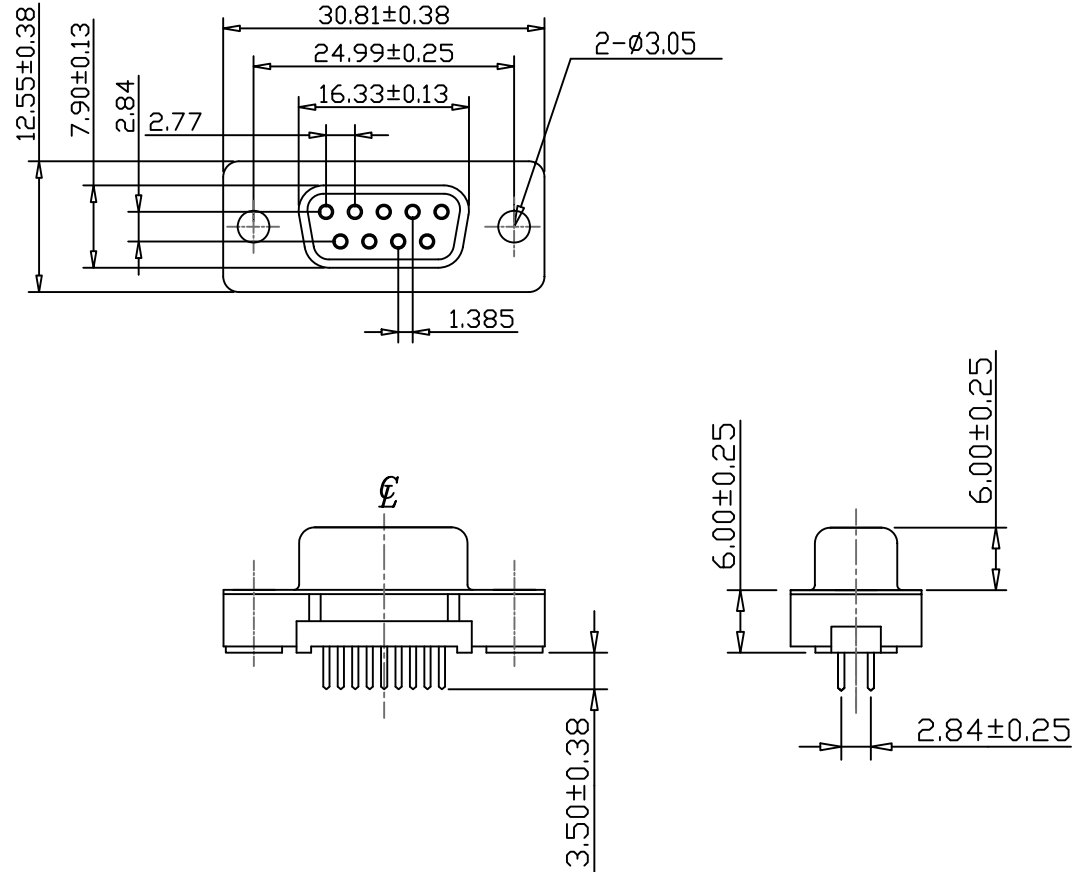

RECOMMENDED P.C.B LAYOUT

RoHS Compliant

TOLERANCES ARE

MORETHANALL
 PCB CONNECTORS
 Cable ASSEMBLIES

煜倫股份有限公司

www.morethanall.com

DRAWING BY CY

CHECKED BY GENIUS

UNIT / mm SCALE 1:1

DATE

SIZE A4

X. ±
 .X ±
 .XX ±
 .XXX ±
 ANG ±

P PROJECTION

照片框

ORDER INFORMATION

DDM-S-09-LF
 SERIES | T LEADFREE
 09WAY
 FEMALE

DESCRIPTION: D-SUB 9 FEMALE STRAIGHT DIP MOUNT