

MATERIALS AND FINISH

SHELL : STEEL MATERIAL, FRONT SHELL NICKEL FINISHED
 BACK SHELL TIN FINISHED
 DIMPLES ON PLUG ONLY
 INSULATOR : PBT THERMOPLASTIC, 30% GLASS
 FILLED, UL 94V-0 RATED, WHITE COLOR
 CONTACT MATERIAL : BRASS
 CONTACT FINISH : FULL GOLD FLASH

ELECTRICAL CHARACTERISTICS

CONTACT CURRENT RATING : 5.0 AMPS
 CONTACT RESISTANCE : 30 MILLIOHMS MAX.
 DIELECTRIC WITHSTANDING VOLTAGE : 1000 V AC MIN.
 INSULATION RESISTANCE : 5000 MEGAOHMS MIN.
 TEMPERATURE RATING : -55°C ~ +105°C

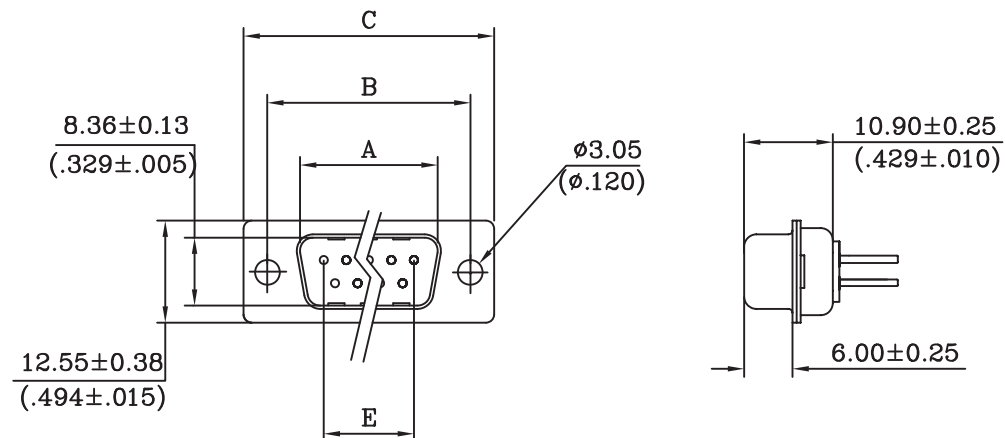

No. of Contact	A ±0.25 ±.010	B ±0.13 ±.005	C ±0.38 ±.015	D ±0.25 ±.010	E
09	16.92 .666	24.99 .984	30.81 1.213	19.28 .759	11.08 .436
15	25.25 .994	33.32 1.312	39.14 1.541	27.51 1.083	19.39 .763
25	38.96 1.534	47.04 1.852	53.04 2.088	41.28 1.625	33.24 1.310
37	55.42 2.182	63.50 2.500	69.32 2.729	57.71 2.272	49.86 1.963

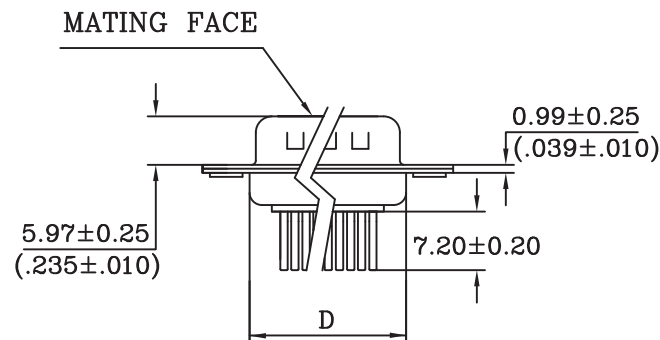

RoHS Compliant

MORETHANALL
 PCB CONNECTORS
 Cable ASSEMBLIES
 煜倫股份有限公司
 www.morethanall.com

DRAWING BY CY
 CHECKED BY GENIUS
 UNIT / mm SCALE 1:1
 DATE

TOLERANCES ARE
 X ±
 .X ±
 .XX ±
 .XXX ±
 ANG ±

SIZE A4 PROJECTION



ORDER INFORMATION

DDL-P072-xx-LF
 SERIES | LEADFREE
 09-37WAY
 DIP 7.2mm
 MALE

DESCRIPTION: