

FRONT VIEW

DB9PIN MALE

DB9PIN FEMALE PANEL

FRONT VIEW

***CONSTRUCTION:

1.CABLE:

* UL2464 24AWG*9C+EA OD:6.0mm BLACK JACKET.

***CONNECTORS:

2.DB9M&F:

- * D-SUB 9PIN MALE& PANEL FEMALE SOLDER TYPE.
- * PINS: BRASS WITH GOLD PLATED.
- * INSULATOR: BLACK COLOR P.B.T UL 94V-0 RATED.
- * SHELL: STEEL WITH NICKEL PLATED.
- * SCREWLOCKS: 5.0*9.4mm, 4-40UNC 2PCS.

3.SHRIK TUBE:

* ϕ 1.5; ϕ 7.0mm BLACK.

4.TEST:

* CT: 2 ohm IS: 5M ohm.

5.PACKING:

* PACK EACH CABLE IN A POLY BAG.

6.MATERIAL:

* MATERIAL WITH RoHS GRADE.

PIN OUT

DB9M	DB9F
1	1
2	2
3	3
4	4
5	5
6	6
7	7
8	8
9	9

DBWDB-0909-E25C5-LF
LEADFREE

RoHS Compliant

	PART NO. DBWDB-0909-E25C5		TOLERANCES ARE .X ± 0.2 .XX ± .XXX ± AWG	DESCRIPTION: DB 9PIN MALE TO DB 9PIN PANEL FEMALE	AREA	REVISIONS	HK	DATE
	DWG NO. DBWDB-0909-E25C5	CHECKED BY CY						
焯倫股份有限公司	FILE NO.		DRAWING BY					
	UNIT / mm	SCALE 1:1	PROJECTION					

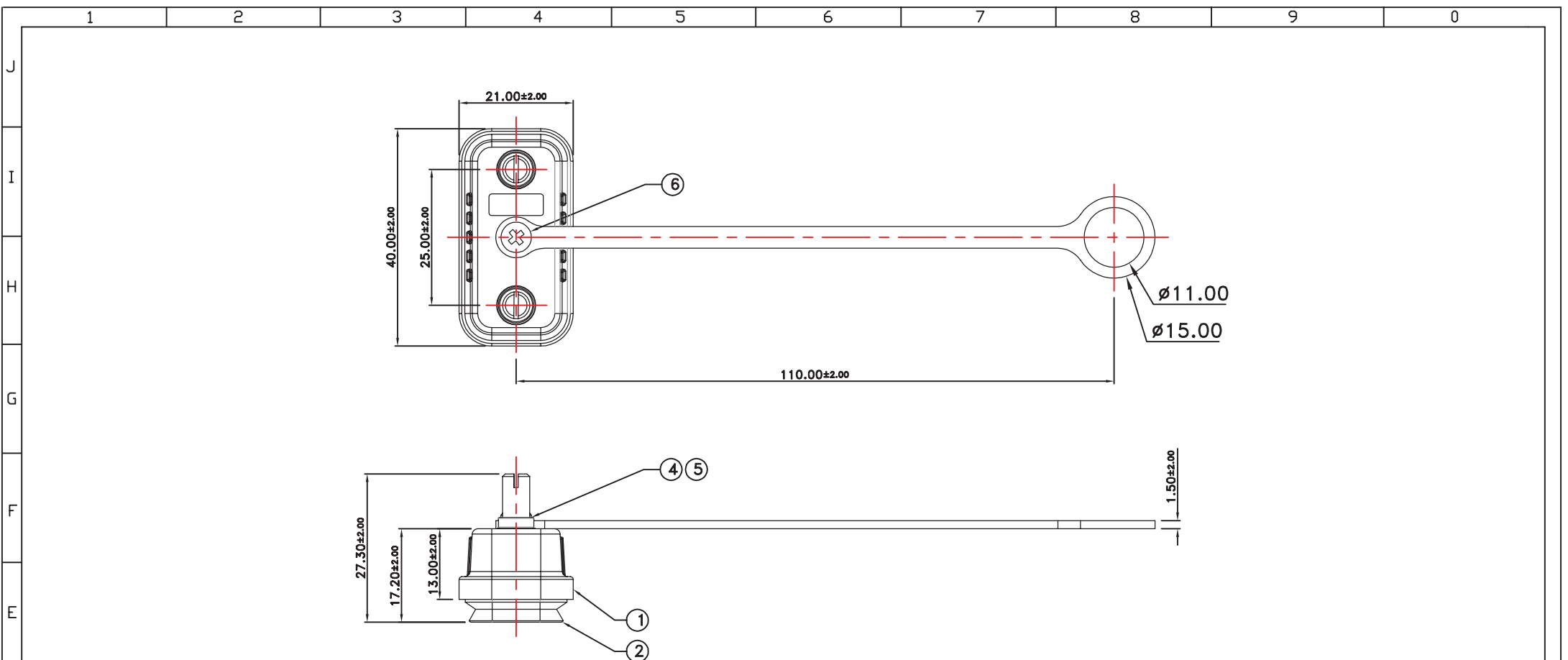

****NOTES:**

1. HOUSING: THERMAL PLASTIC BLACK COLOR.
2. RUBBER PAD: EPDM BLACK COLOR.
3. RUBBER CHAIN: THERMAL PLASTIC BLACK COLOR.
4. MACHINE SCREW: COPPER ALLOY NICKEL PLATED.
5. GASKET: EPDM BLACK COLOR.
6. MACHINE SCREW: STAINLESS.

	PART NO. DBWDB-0909-E25C5		CHECKED BY CY	TOLERANCES ARE .X ± 0.2 .XX ± .XXX ± AWG	DESCRIPTION: D-SUB PANEL CAP, WITH RUBBER CHAIN			
	DWG NO. DBWDB-0909-E25C5				DRAWING BY	AREA	REVISIONS	HK
煜倫股份有限公司	FILE NO.		PROJECTION					
	UNIT / mm	SCALE 1:1						