

NOTES:
 1.100% TEST OPEN, SHORT & MISWIRE.
 2.PACKING: 1PC/BAG.

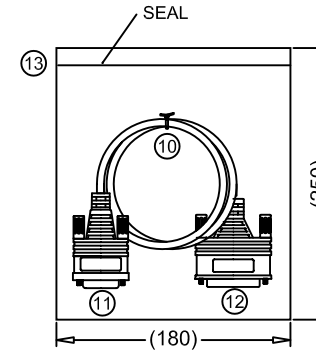

ITEM	QTY	PART NUMBER	DESCRIPTION
13	1	PE BAG	180x250x0.05mm
12	1	DUST COVER	FOR DB25P MALE
11	1	DUST COVER	FOR LFH60P MALE
10	1	MINI TIE	COLOR GRAY
9	1	OUTER MOLD	PVC 45P COLOR IRON GRAY (2-04) /MOLD NO. WH60001
8	1	SHIELD CASE	FOR LFH60P MALE ID.9.5mm
7	1	CONNECTOR	LFH60P MALE CONTACT GOLD PLATED 15U" INSULATION BLACK SHELL NICKEL PLATED
6	4	SCREW	4x33.7mm #4-40UNC PVC COLOR IRON GRAY (2-04) /SC-40-0037
5	1	OUTER MOLD	PVC 45P COLOR IRON GRAY (2-04) /MOLD NO. WD25001
4	1	COPPER FOIL	30x100mm (360° SOLDER)
3	1	INNER MOLD	PE OR PVC
2	1	CONNECTOR	DB25P MAEL SOLDER TYPE INSULATION BLACK SHELL NICKEL PLATED
1	1	CABLE	(UL) TYPE CL2 28AWGx12.5P+ADB OD.8.5mm JACKET COLOR IRON GRAY (2-04)
PARTS LIST			

MORETHANALL
 CONNECTORS
 ASSEMBLIES

PART NO. **DBLFH-2560-M6F**

DWG NO. **DBLFH-2560-M6F**

CHECKED BY CY

TOLERANCES ARE

DESCRIPTION:

煜倫有限公司

FILE NO.

DRAWING BY

.X ±
.XX ±
.XXX ±
AWG

AREA

REVISIONS

HK

DATE

UNIT / mm

SCALE 1:1

PROJECTION

