

1 2 3 4 5 6 7 8 9 0

J

I

H

G

F

E

D

C

B

A

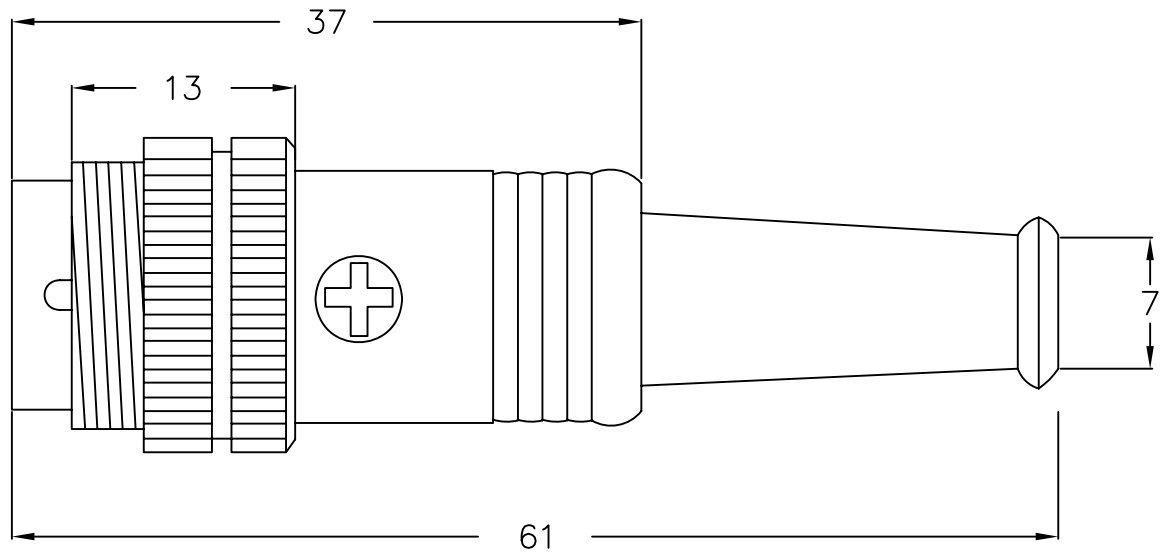
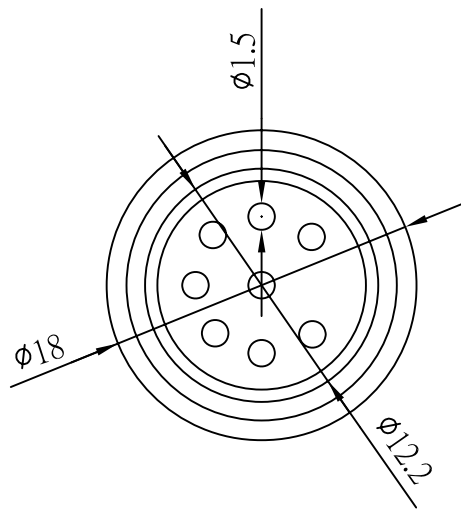

DAMS-PA-08-LF
LEADFREE

RoHS Compliant

MORETHANALL
CONNECTORS
ASSEMBLIES

PART NO.	DAMS-PA-08	APPROVED BY	CY	TOLERANCES ARE	DESCRIPTION:	8P DIN PLUG SCREW ON TYPE			
DWG NO.	DAMS-PA-08	DRAWING BY		.X ± 0.38 .XX ± 0.25 .XXX ± 0.13 AWG					
UNIT / mm	SCALE 1:1	PROJECTION		AREA	REVISIONS	HK	DATE		

焜倫股份有限公司