

ARRANGEMENT OF CONTACTS

PARTS	DAMS-JSPAN-03	DAMS-JSPAN-04	DAMS-PAN-05	DAMS-JSPAN-05B	DAMS-JSPAN-06	DAMS-JSPAN-07	DAMS-JSPAN-08
ANGLE	180°	216°	180°	240°	240°	270°	270°
POSITION OF VIEWS							

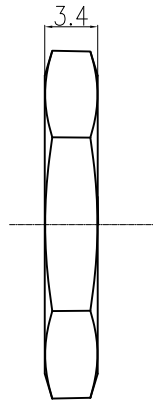
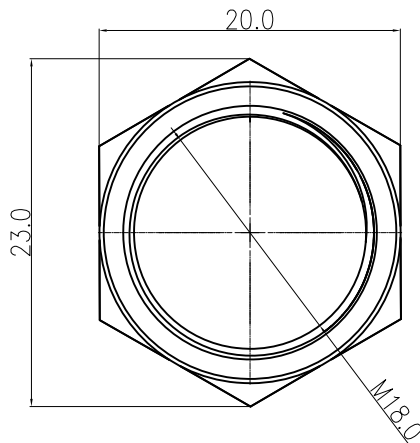
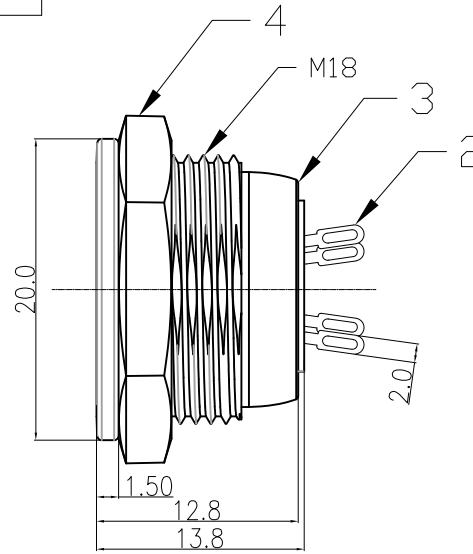
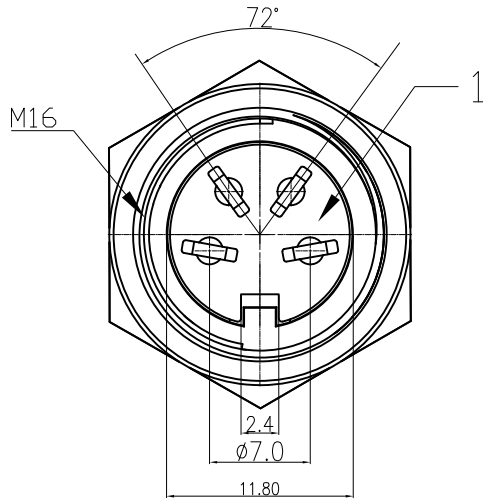
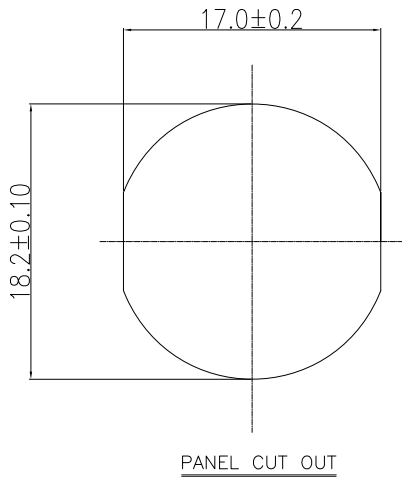

SPECIFICATIONS:

- CONTACT RESISTANCE: 20 MINI OHM MAX.
- INSULATION RESISTANCE: 100M OHM AT 500V D.C
- DIELECTRIC STRENGTH: 1,000V AC FOR ONE MINUTE
- RATING: 100V AC 2A.

5					
4	HEX. NUT	1	DIECAST ALLOY	NICKEL	30-50U"
3	METAL BODY	1	DIECAST ALLOY	NICKEL	30-50U"
2	CONTACT TERMINAL	3-8	BSR-H(0.6t) c2680R	TIN	30-50U"
1	PLASTIC CORE	1	P.B.T 4815	BLACK	UL94V0
P/N	PART NAME	Q'TY	MATERIAL	PLATING&COLOR	REMARKS

RoHS Compliant

TOLERANCES ARE

**MORETHANALL**  
PCB CONNECTORS  
Cable ASSEMBLIES

DRAWING BY CY

X. ± 0.50

CHECKED BY GENIUS

.X ± 0.30

UNIT / mm

SCALE 1:1

.XX ± 0.20

DATE

.XXX ±

ANG ±

SIZE A4

PPOJECTION

照片框

ORDER INFORMATION

DAMS-JSPAN-xx-LF

SERIES LEADFREE  
03-08WAY  
NUT  
PANEL FRONT  
SOLDER  
JACK

DESCRIPTION:

煜倫股份有限公司

www.morethanall.com